

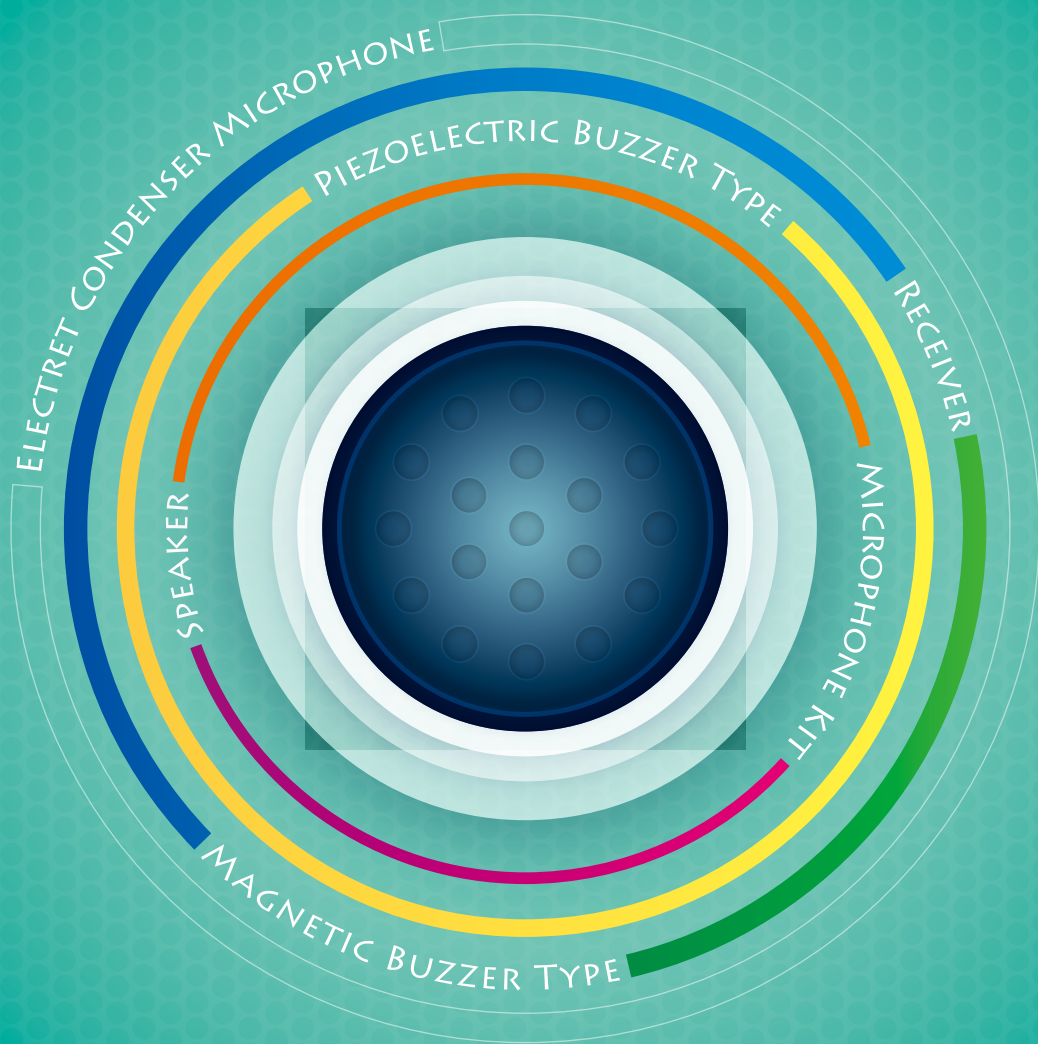

Ariose Electronics Co., Ltd.



Color the **a**coustic World

[www.ario.com.tw](http://www.ario.com.tw)



# COMPANY

公司簡介

Ariose Electronics Co., Ltd.

## 關於我們 About us

音賜股份有限公司創立於1996年，是值得信賴且富有經驗的「電聲元件專業製造商」。

Founded in 1996, Ariose Electronics Co., Ltd. is a reliable, well-developed and professional manufacturer with well experiences in the electronic acoustic field.

## 主要產品 Main Products

蜂鳴器、喇叭、音箱、電容式麥克風、聆賞音樂用立體耳機組、藍芽無線傳輸通訊用途的耳機組、外接式麥克風組等。

Buzzer, Speaker, Speaker box, Electret Condenser Microphone, Stereo Headphone Set for multi-media, Earphone Set for communication and handsfree application.

## 產品適用於 Application

手持式消費性電子產品、手持式無線傳輸電子產品。各式電子、電機量測儀器、醫療儀器與醫療器材、自動化設備、機器人與自動控制設備、家電產品、汽機車警式功能與儀錶警示裝置、大樓消防與安全系統警示設備、居家用安全系統與警報系統等。

Consumer electronics for PDA, GPS, MP3, PMP, DSC, mobile phone, e-book, wireless transmission devices (Bluetooth, WiFi, WiMAX, and so on), electronic measuring instrument, medical instrument, automatic control device and home appliances, automotive alarm device, fire alarm equipment, security system and etc.

## 前瞻與方向 Future

在電子產品要求：輕薄短小，品質穩定，優惠價格的市場需求趨勢，音賜將以堅實的產品開發能力，豐富的產品應用開發經驗，滿足客戶對電聲產品的需求。

Manufacture small size products with great quality and competitive price based on the trends toward the market of electronic components. We support customers via our innovative abilities and full experiences to meet their acoustic requirements.



**經營理念 Company management philosophy :**

- ◎ 誠信負責 / Integrity and Responsibility.
- ◎ 專業用心 / Professional and Whole-hearted.
- ◎ 創新發展 / Innovation and Development.
- ◎ 成果分享 / Achievements sharing.

**環境政策 Environment Policy :**

- ◎ 遵行環保政策規範 / Follow Environmental Protection Rules and Regulations.
- ◎ 減廢減碳降低能耗 / Energy Saving and Carbon Reduction.
- ◎ 污染預防資源回收 / Resource Recycling and Pollution Prevention.
- ◎ 綠色生產永續經營 / Green Manufacturing and Sustainable Development.

**品質政策 Quality Policy :**

- ◎ 品質第一，持續改善 / Quality comes first with continuous improvement.
- ◎ 全員參與，客戶滿意 / Satisfy the clients, with everyone's involvement.



# Piezoelectric Buzzer Type

壓電式蜂鳴器



## Piezoelectric Type

Description of Part No. of Piezoelectric type series

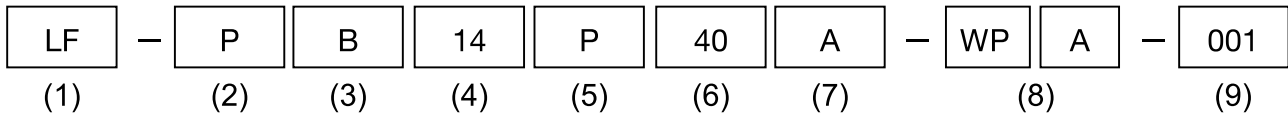

- (1) LF : Compliant with RoHS requirement.  
  : Not compliant with RoHS requirement.

(2) Piezoelectric type

(3) B: Buzzer for driver circuit built-in

K: Speaker

S: Sounder for self drive

A: Speaker with amplifier

E: Sounder for external drive

(4) Diameter (mm) :

i.e.: 24.4 will be indicated as 24.0mm ; 24.5 will be 25.0mm

(5) Connection method

- ◆ P : Pin type (PCB mounting )
- ◆ T : SMD package
- ◆ W: Lead wire type
- ◆ S : The single part of Piezoelectric speaker without any fitting

(6) Resonant Frequency (KHz)

i.e. : 4,000Hz will be indicated as 40 ;700Hz will be 07.

(7) A~ Z to stand for different versions

(8) IP Rating

Without clearly IP Rating will be marked as “WP” only

(9) Serial number

# Piezoelectric Buzzer Type | 壓電式蜂鳴器

+ Piezoelectric buzzer 壓電式蜂鳴器

## ◎ LF-PB14T40A-A

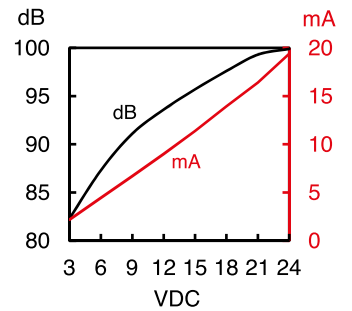
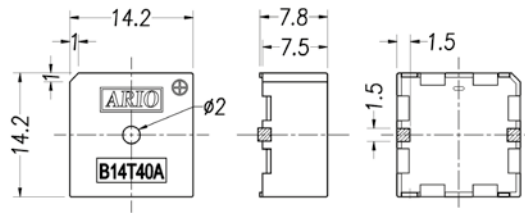

## ◎ LF-PB14P40A

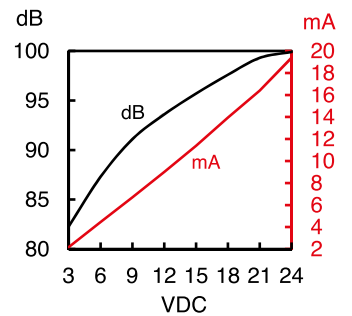
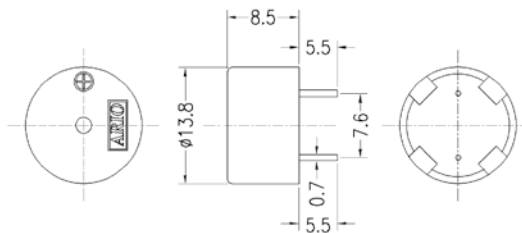

## ◎ LF-PB14P40D

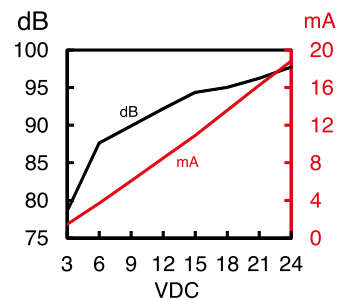
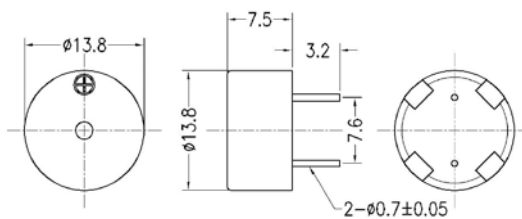

## ◎ LF-PB14P40H

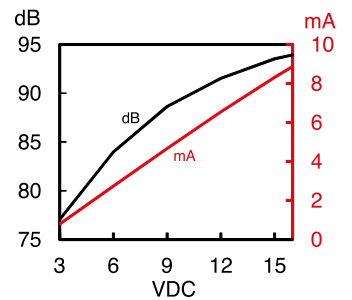
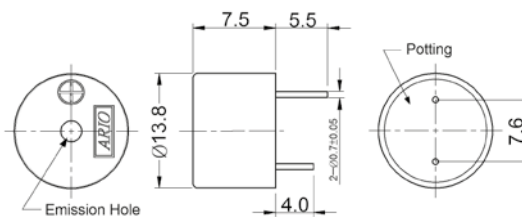

Part No. 型號	※SPL. (dB min.) 輸出音壓	※Current Consumption(mA) 消耗電流	Oscillating Frequency (±0.5KHz) 振盪頻率	Operating Voltage (VDC) 工作電壓	Operating Temp. (°C) 工作溫度
LF-PB14T40A-A	88	8.0 max.	4.5 Continuous tone	3~24	-20~+85
LF-PB14P40A	88	8.0 max.	4.3 Continuous tone	3~24	-20~+70
LF-PB14P40D	85	8.0 max.	4.3 Continuous tone	3~24	-20~+85
LF-PB14P40H	85	7.0max.	4.0 Continuous tone	3~16	-30~+70

※ At 9VDC/10cm.

# Piezoelectric Buzzer Type | 壓電式蜂鳴器

Ariose Electronics Co., Ltd.

+ Piezoelectric buzzer 壓電式蜂鳴器

## ◎ LF-PB24P34A

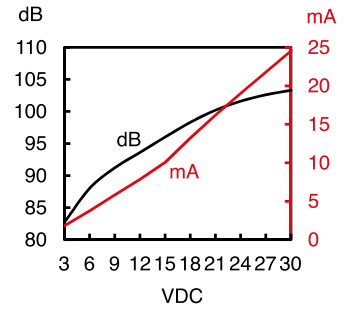
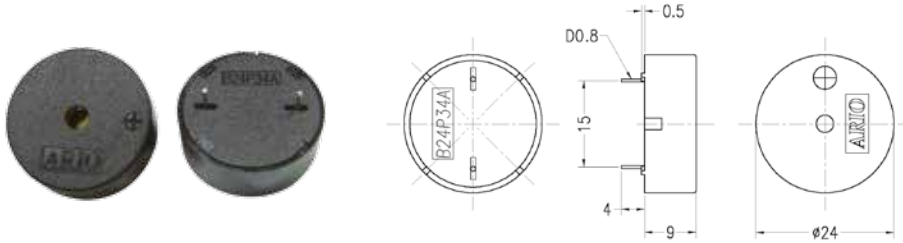

## ◎ LF-PB24P34B

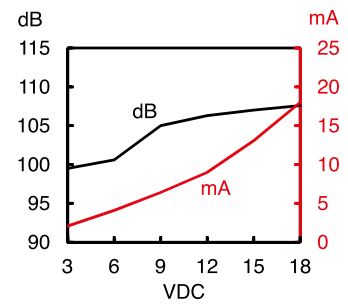
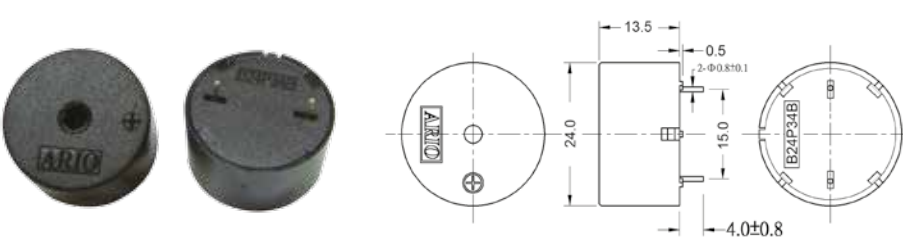

## ◎ LF-PB24P34D

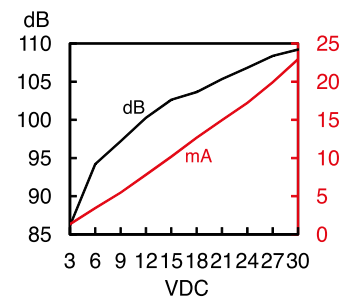
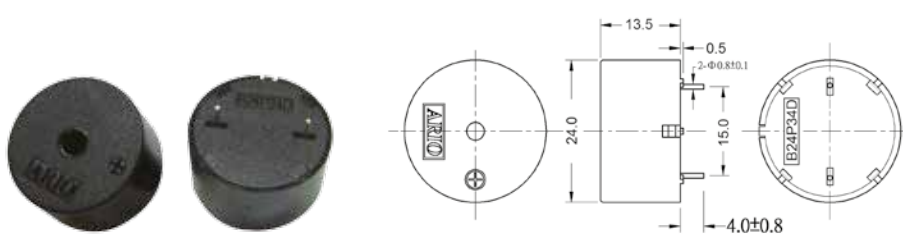

Part No. 型號	※SPL. (dB min.) 輸出音壓	※Current Consumption(mA) 消耗電流	Oscillating Frequency (±0.5KHz) 振盪頻率	Operating Voltage (VDC) 工作電壓	Operating Temp. (°C) 工作溫度
LF-PB24P34A	90	7.0 max.	3.4 Continuous tone	3~30	-20~+85
LF-PB24P34B	100	8.0 max.	3.0 Continuous tone	3~18	-20~+85
LF-PB24P34D	93	8.0 max.	3.5 Continuous tone	3~30	-20~+85

※ At 9VDC/10cm.

# Piezoelectric Buzzer Type | 壓電式蜂鳴器

+ Piezoelectric buzzer 壓電式蜂鳴器

## ◎ LF-PB24P34E / LF-PB24P34G

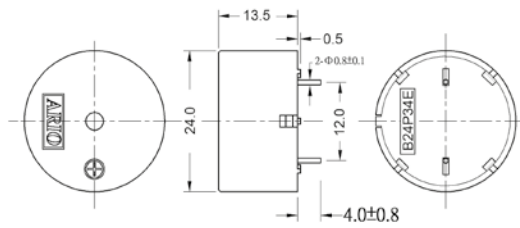

LF-PB24P34E Pitch:12.0mm

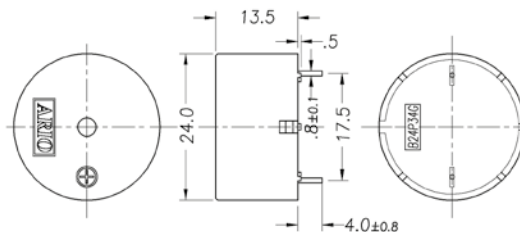
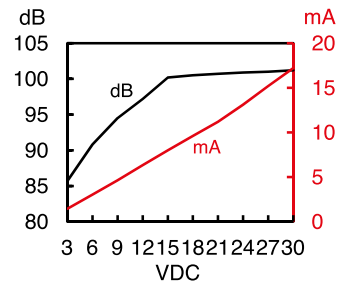

LF-PB24P34G Pitch:17.5mm

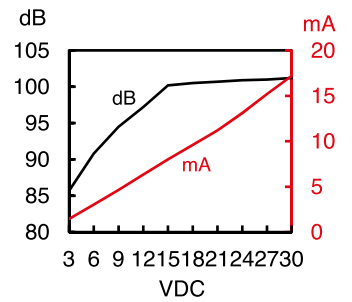

## ◎ LF-PB24P34F-001

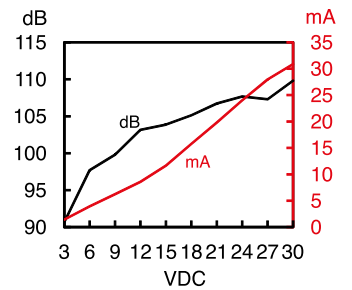
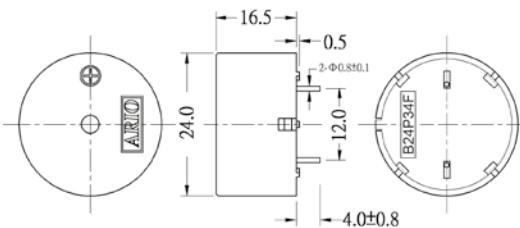

## ◎ LF-PB25P32A

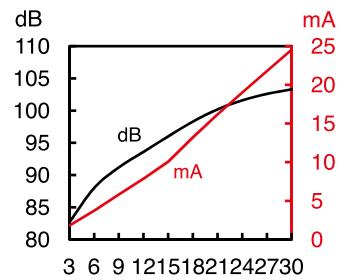
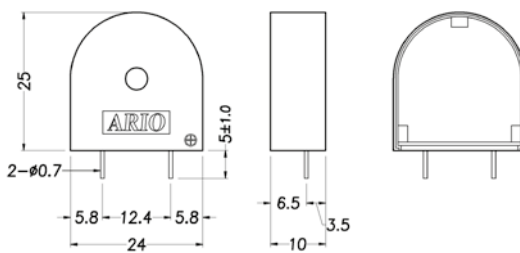

Part No. 型號	※SPL. (dB min.) 輸出音壓	※Current Consumption(mA) 消耗電流	Oscillating Frequency (±0.5KHz) 振盪頻率	Operating Voltage (VDC) 工作電壓	Operating Temp. (°C) 工作溫度
LF-PB24P34E	93	8.0 max.	3.0 Continuous tone	3~30	-20~+85
LF-PB24P34G	93	8.0 max.	3.0 Continuous tone	3~30	-20~+85
LF-PB24P34F-001	98	10.0 max.	3.4 Continuous tone	3~30	-20~+85
LF-PB25P32A	92	8.0 max.	3.2 Continuous tone	3~30	-20~+85

※ At 9VDC/10cm.



# Piezoelectric Buzzer Type | 壓電式蜂鳴器

Ariose Electronics Co., Ltd.

+ Piezoelectric buzzer 壓電式蜂鳴器

## ◎ LF-PB30P25A / LF-PB30P25A-A / LF-PB30P25B / LF-PB30P25B-A

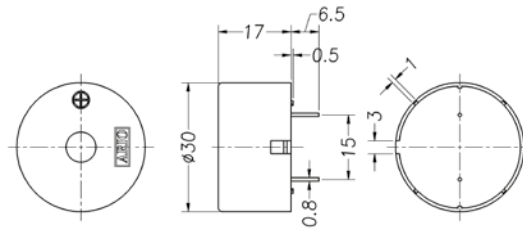

LF-PB30P25A Pitch:15mm

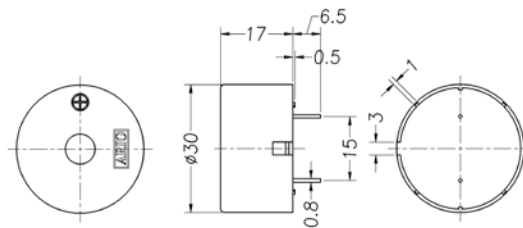
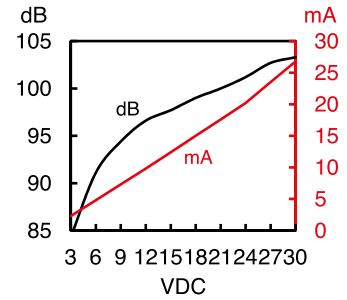

LF-PB30P25A-A Pitch:15mm

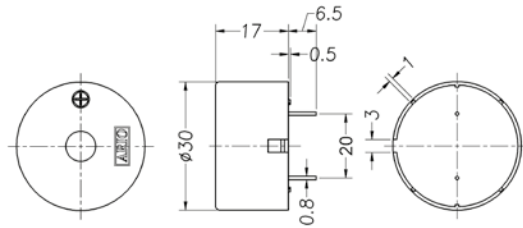
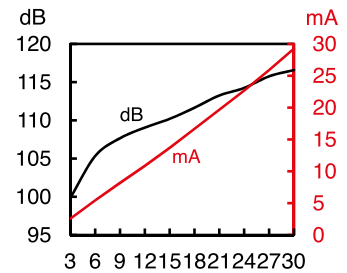

LF-PB30P25B Pitch:20mm

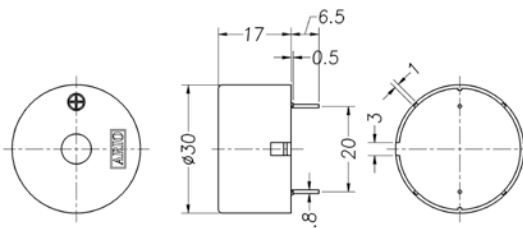
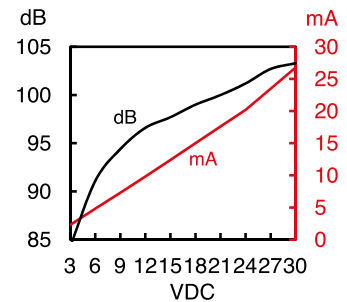

LF-PB30P25B-A Pitch:20mm

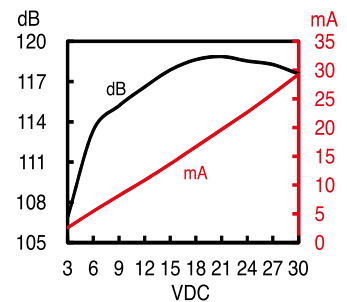

Part No. 型號	※SPL. (dB min.) 輸出音壓	※Current Consumption(mA) 消耗電流	Oscillating Frequency (±0.5KHz) 振盪頻率	Operating Voltage (VDC) 工作電壓	Operating Temp. (°C) 工作溫度
LF-PB30P25A	88	8.0 max.	2.5 Continuous tone	3~30	-20~+85
LF-PB30P25A-A	98	16.0 max.	2.5 Continuous tone	3~30	-20~+85
LF-PB30P25B	88	8.0 max.	2.5 Continuous tone	3~30	-20~+85
LF-PB30P25B-A	110	16.0 max.	2.5 Continuous tone	3~30	-20~+85

※ At 9VDC/10cm.

Piezoelectric Buzzer 壓電式蜂鳴器

# Piezoelectric Buzzer Type | 壓電式蜂鳴器

+ Piezoelectric buzzer 壓電式蜂鳴器

## ◎ LF-PB30P35A

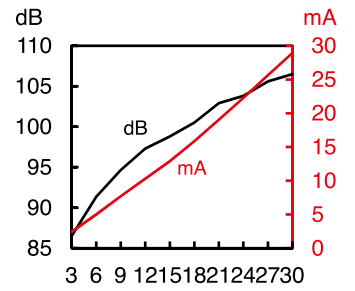
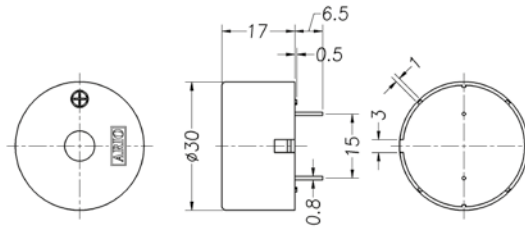

## ◎ LF-PB30P39A

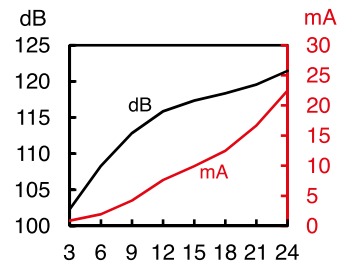
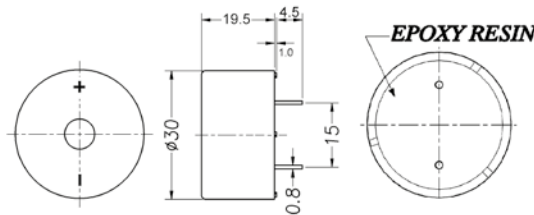

Piezoelectric Buzzer

壓電式蜂鳴器

Part No. 型號	※SPL. (dB min.) 輸出音壓	※Current Consumption(mA) 消耗電流	Oscillating Frequency (±0.5KHz) 振盪頻率	Operating Voltage (VDC) 工作電壓	Operating Temp. (°C) 工作溫度
LF-PB30P35A	93 註 1	12.0 max.	3.5 Continuous tone	3~30	-20~+85
LF-PB30P39A	100	15.0 max.	3.9 Continuous tone	3~24	-20~+80

※ At 9VDC/10cm. 註 1: At 12VDC/30cm.

# Piezoelectric Buzzer Type | 壓電式蜂鳴器

Ariose Electronics Co., Ltd.

+ Piezoelectric buzzer 壓電式蜂鳴器

## ◎ LF-PB42P29A / LF-PB42P29B / LF-PB42P29C / LF-PB42P29D

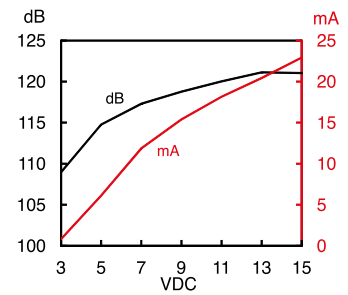
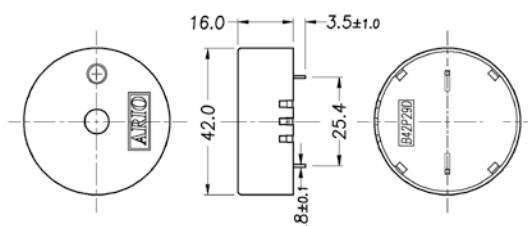
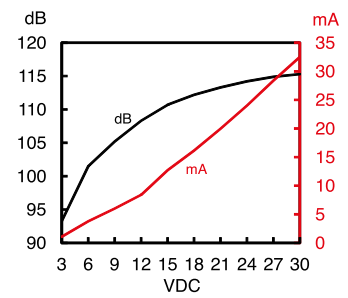
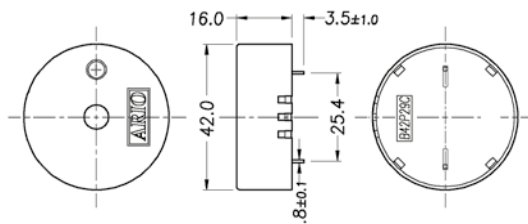
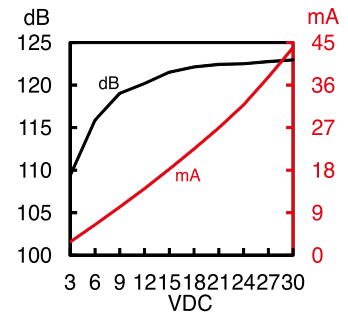
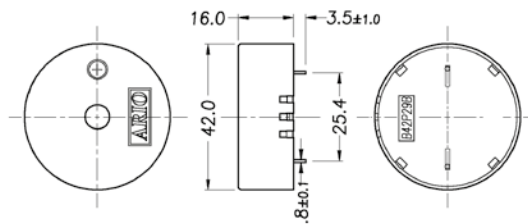
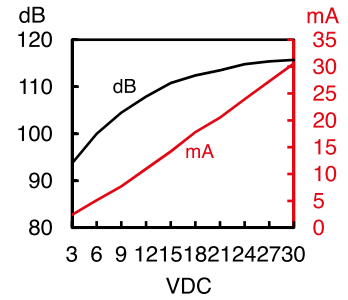
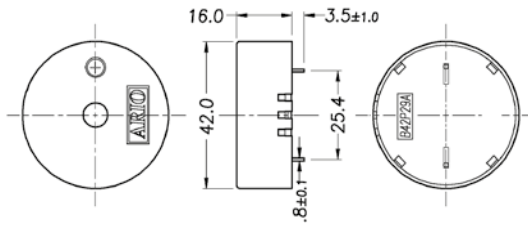

Part No. 型號	※SPL. (dB min.) 輸出音壓	※Current Consumption(mA) 消耗電流	Oscillating Frequency (±0.5KHz) 振盪頻率	Operating Voltage (VDC) 工作電壓	Operating Temp. (°C) 工作溫度
LF-PB42P29A	90	10.0 max.	2.9 Continuous tone	3~30	-20~+85
LF-PB42P29B	106	13.0 max.	2.9 Continuous tone	3~30	-20~+85
LF-PB42P29C	100	12.0 max.	2.9 Pulse tone	3~30	-20~+85
LF-PB42P29D	110	20.0 max.	2.9 Dual tone	3~15	-20~+85

※ At 9VDC/10cm.

Piezoelectric Buzzer 壓電式蜂鳴器

# Piezoelectric Buzzer Type | 壓電式蜂鳴器

+ Piezoelectric buzzer 壓電式蜂鳴器

## ◎ LF-PB43P28A

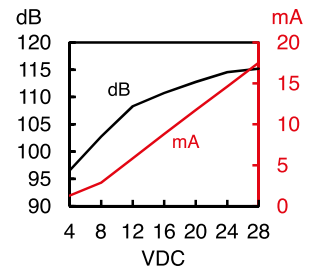
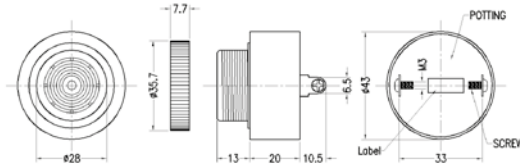

## ◎ LF-PB43P28C

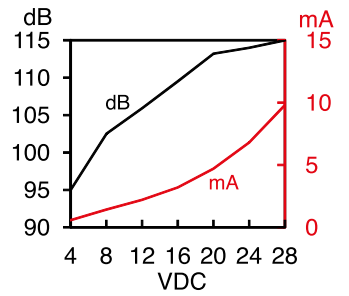
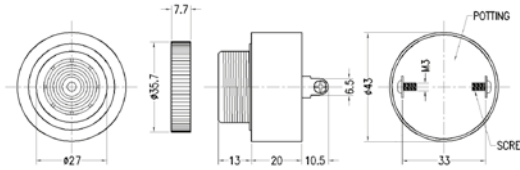

## ◎ LF-PB43P28D

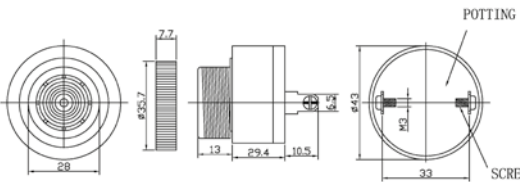

Part No. 型號	※SPL. (dB min.) 輸出音壓	※Current Consumption(mA) 消耗電流	Oscillating Frequency (±0.5KHz) 振盪頻率	Operating Voltage (VDC) 工作電壓	Operating Temp. (°C) 工作溫度
LF-PB43P28A	95 At 9VDC/10cm	6.0 max. At 9VDC/10cm	2.8 Continuous tone	4~28	-20~+60
LF-PB43P28C	100 At 12VDC/10cm	8.0 max. At 12VDC/10cm	2.8 Continuous tone	4~28	-20~+60
LF-PB43P28D	91 At 220VAC/10cm	16.0max. At 220VAC/10cm	2.8 Fast Pulse tone	60~250 VDC/AC	-20~+60

## ◎ LF-PB43P29A(Fast tone)

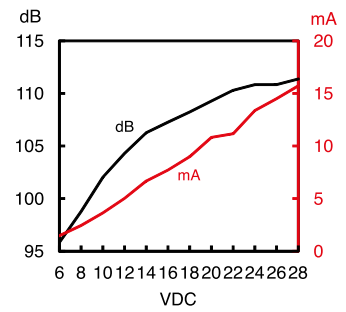
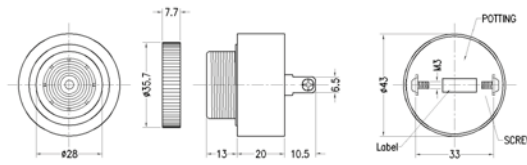

## ◎ LF-PB43P29B(Slow tone)

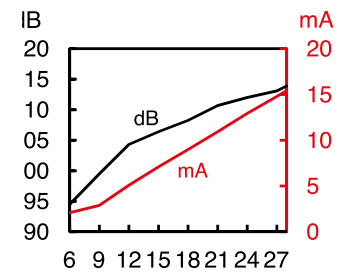
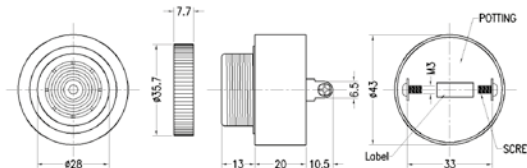

Part No. 型號	※SPL. (dB min.) 輸出音壓	※Current Consumption(mA) 消耗電流	Oscillating Frequency (±0.5KHz) 振盪頻率	Operating Voltage (VDC) 工作電壓	Operating Temp. (°C) 工作溫度
LF-PB43P29A	98 At 12VDC/10cm	8.0 max. At 12VDC/10cm	2.9 Fast tone	6~28	-20~+60
LF-PB43P29B	95 At 9VDC/10cm	6.0 max. At 9VDC/10cm	2.9 Slow tone	6~28	-20~+60



# Piezoelectric Buzzer Type | 壓電式蜂鳴器

+ Piezoelectric buzzer 壓電式蜂鳴器

## ◎ LF-PB24W34A

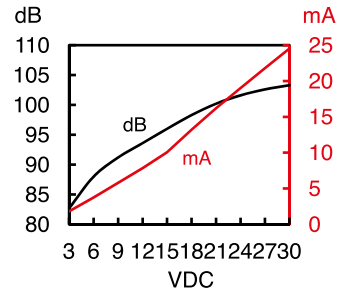
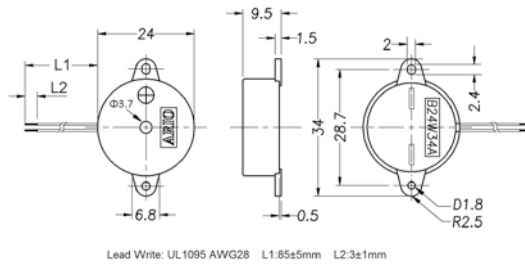

## ◎ LF-PB28W35A

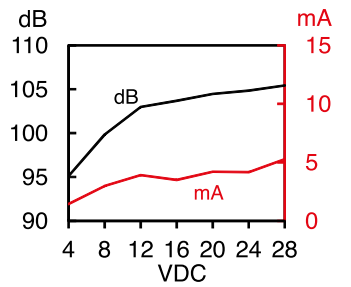
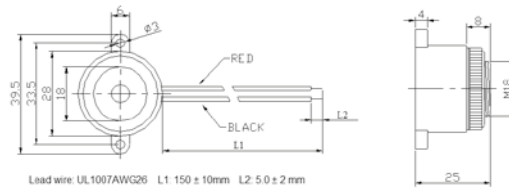

Piezoelectric Buzzer 壓電式蜂鳴器

Part No. 型號	※SPL. (dB min.) 輸出音壓	※Current Consumption(mA) 消耗電流	Oscillating Frequency (±0.5KHz) 振盪頻率	Operating Voltage (VDC) 工作電壓	Operating Temp. (°C) 工作溫度
LF-PB24W34A	90	7.0 max.	3.4 Continuous tone	3~30	-20~+85
LF-PB28W35A	100 註 1	10.0 max.	3.5 Fast Pulse tone	4~28	-20~+60

※ At 9VDC/10cm. 註 1: At 12VDC/10cm.

# Piezoelectric Buzzer Type | 壓電式蜂鳴器

Ariose Electronics Co., Ltd.

+ Piezoelectric buzzer 壓電式蜂鳴器

## ◎ LF-PB30W25A / LF-PB30W25B

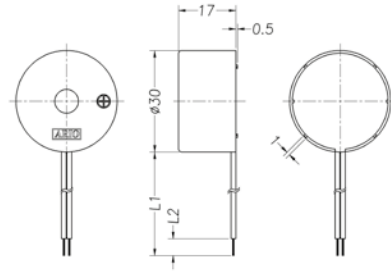

Lead Wire: UL 1095 AWG28 L1: 80 ± 5mm L2: 3.0 ± 1mm

LF-PB30W25A

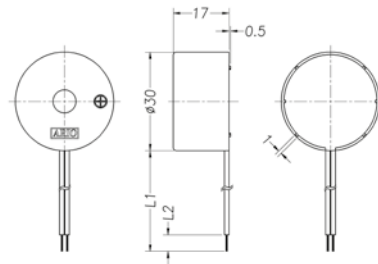
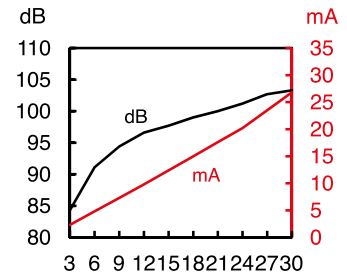

Lead Wire: UL 1095 AWG28 L1: 80 ± 5mm L2: 3 ± 1mm

LF-PB30W25B

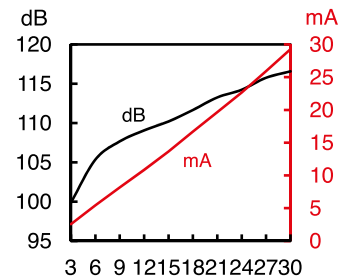

## ◎ LF-PB30W25C

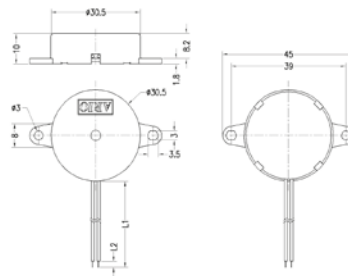

Lead Wire: UL 1095 AWG28 L1: 80 ± 5mm L2: 3.0 ± 1mm

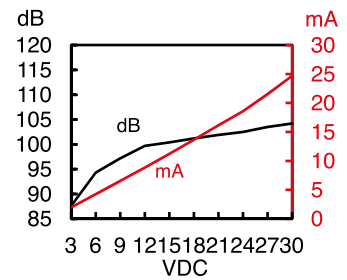

Piezoelectric Buzzer 壓電式蜂鳴器

Part No. 型號	※SPL. (dB min.) 輸出音壓	※Current Consumption(mA) 消耗電流	Oscillating Frequency (±0.5KHz) 振盪頻率	Operating Voltage (VDC) 工作電壓	Operating Temp. (°C) 工作溫度
LF-PB30W25A	95	9.0 max.	2.5 Continuous tone	3~30	-20~+70
LF-PB30W25B	98	16.0 max.	2.5 Continuous tone	3~30	-20~+70
LF-PB30W25C	94	7.0 max.	2.5 Continuous tone	3~30	-20~+70

※ At 9VDC/10cm.

# Piezoelectric Buzzer Type | 壓電式蜂鳴器

+Piezoelectric buzzer 壓電式蜂鳴器

## ◎ LF-PB30W32A / LF-PB30W32A-12 / LF-PB30W35A-12 / LF-PB30W35A-24

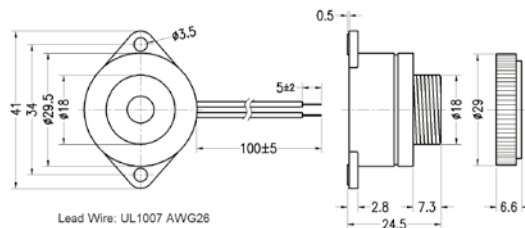

Lead Wire: UL1007 AWG26

LF-PB30W32A

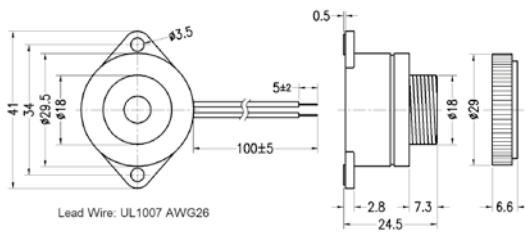
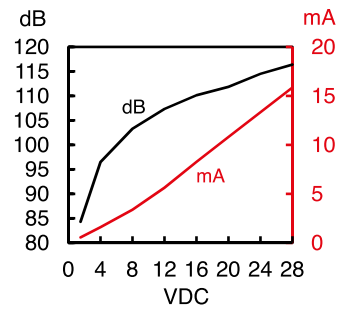

Lead Wire: UL1007 AWG26

LF-PB30W32A-12

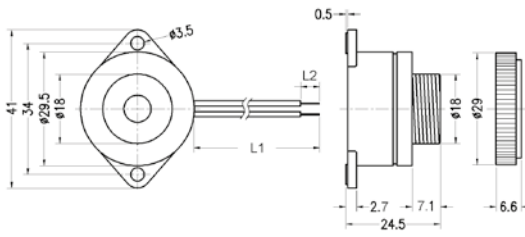
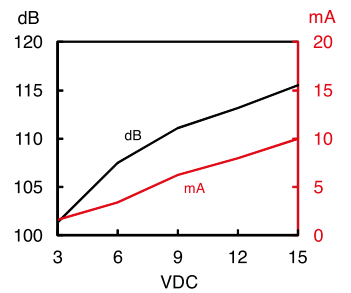

Lead wire:UL1007 AWG 26 L1:100 ± 5.0 mm L2:5 ± 2.0 mm

LF-PB30W35A-12

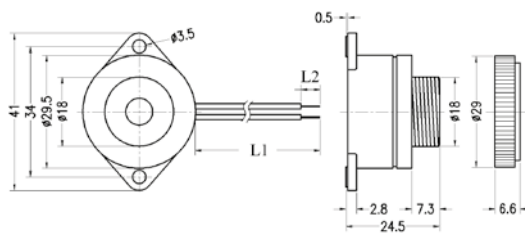
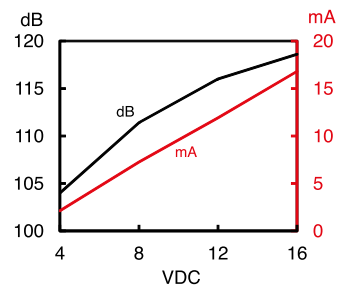

Lead wire: UL1007 AWG 26 L1:100 ± 5.0 mm L2:5 ± 2.0 mm

LF-PB30W35A-24

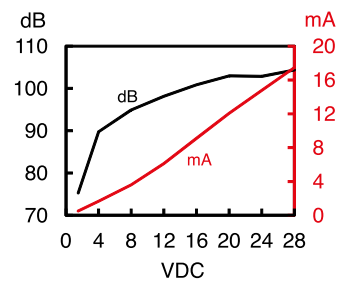

Piezoelectric Buzzer 壓電式蜂鳴器

Part No. 型號	※SPL. (dB min.) 輸出音壓	※Current Consumption(mA) 消耗電流	Oscillating Frequency (±0.5KHz) 振盪頻率	Operating Voltage (VDC) 工作電壓	Operating Temp. (°C) 工作溫度
LF-PB30W32A	100 At 24VDC/10cm	20.0 max. At 24VDC/10cm	3.2 Continuous tone	1.5~28	-20~+60
LF-PB30W32A-12	100 At 12VDC/10cm	12.0 max. At 12VDC/10cm	3.2 Pulse tone	3~15	-20~+60
LF-PB30W35A-12	100 At 12VDC/10cm	15.0 max. At 12VDC/10cm	3.5 Continuous tone	1.5~16	-20~+60
LF-PB30W35A-24	95 At 24VDC/30cm	20.0 max. At 24VDC/30cm	3.5 Continuous tone	1.5~28	-20~+60

# Piezoelectric Buzzer Type | 壓電式蜂鳴器

Ariose Electronics Co., Ltd.

+ Piezoelectric buzzer 壓電式蜂鳴器

## ◎ LF-PB30W35B

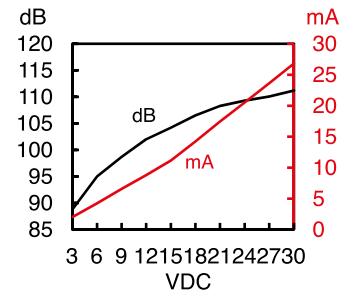
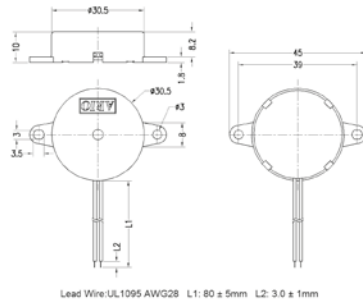

## ◎ LF-PB32W37A-A

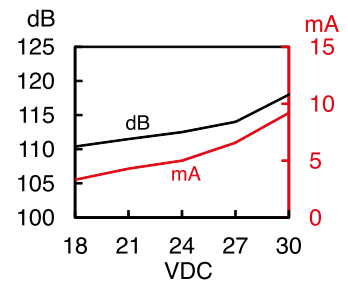
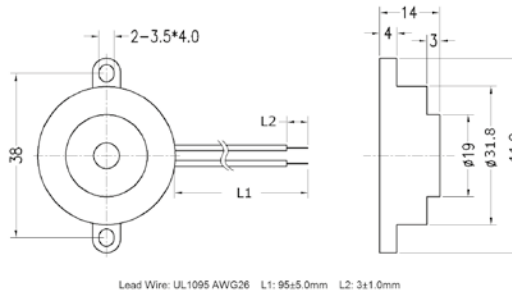

Piezoelectric Buzzer 壓電式蜂鳴器

Part No. 型號	※SPL. (dB min.) 輸出音壓	※Current Consumption(mA) 消耗電流	Oscillating Frequency (±0.5KHz) 振盪頻率	Operating Voltage (VDC) 工作電壓	Operating Temp. (°C) 工作溫度
LF-PB30W35B	90 At 9VDC/10cm	9.0 max. At 9VDC/10cm	3.5 Continuous tone	3~30	-20~+70
LF-PB32W37A-A	110 At 24VDC/10cm	20.0 max. At 24VDC/10cm	3.7 Continuous tone	18~30	-20~+60

# Piezoelectric Buzzer Type | 壓電式蜂鳴器

+ Piezoelectric buzzer 壓電式蜂鳴器

## ◎ LF-PB42W29A

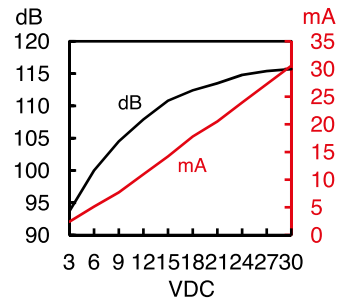
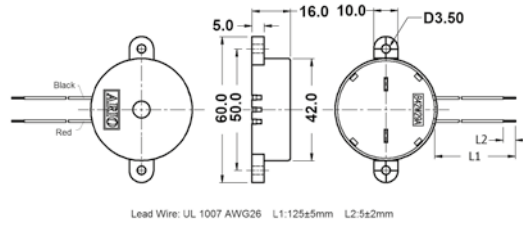

## ◎ LF-PB42W29B

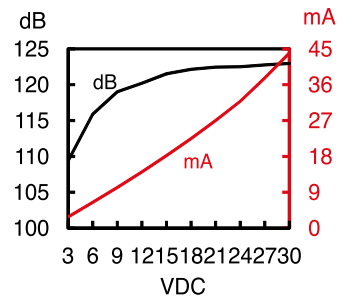
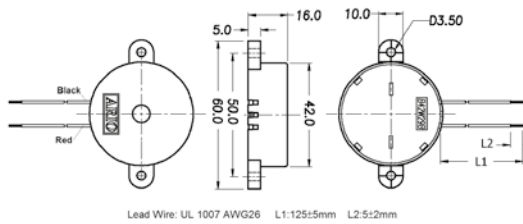

## ◎ LF-PB42W29C

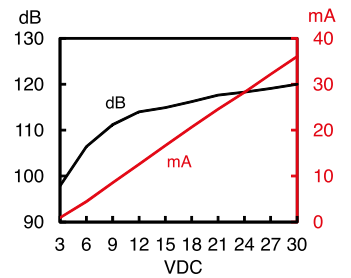
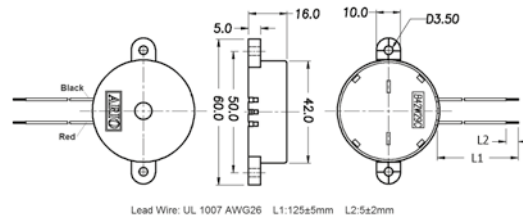

## ◎ LF-PB42W29D

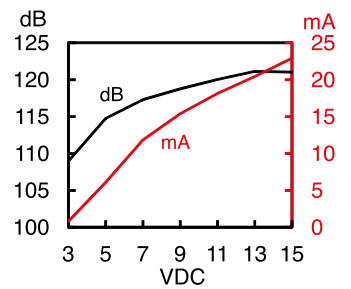
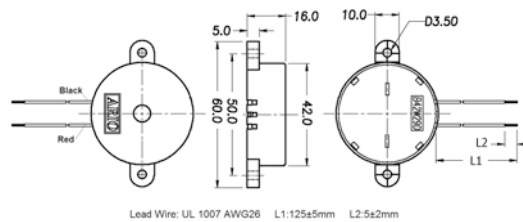

Part No. 型號	※SPL. (dB min.) 輸出音壓	※Current Consumption(mA) 消耗電流	Oscillating Frequency (±0.5KHz) 振盪頻率	Operating Voltage (VDC) 工作電壓	Operating Temp. (°C) 工作溫度
LF-PB42W29A	102	9.0 max.	2.9 Continuous tone	3~30	-20~+85
LF-PB42W29B	106	13.0 max.	2.9 Continuous tone	3~30	-20~+85
LF-PB42W29C	103	11.0 max.	2.9 Pulse tone	3~30	-20~+85
LF-PB42W29D	110	20.0 max.	2.9 Dual tone	3~15	-20~+85

※ At 9VDC/10cm.



### ◎ LF-PB42W29E

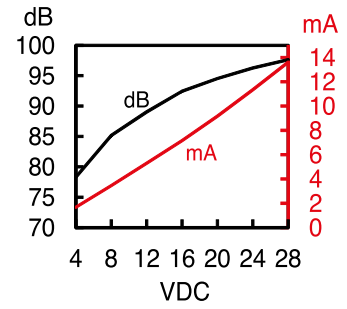
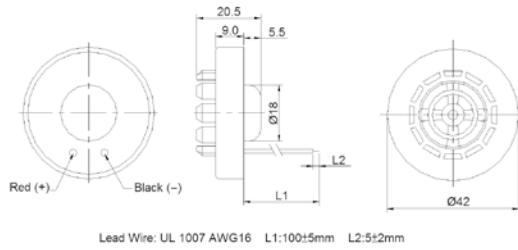

Part No. 型號	※SPL. (dB min.) 輸出音壓	※Current Consumption(mA) 消耗電流	Oscillating Frequency (±0.5KHz) 振盪頻率	Operating Voltage (VDC) 工作電壓	Operating Temp. (°C) 工作溫度
LF-PB42W29E	85	10.0 max.	2.9 Continuous tone	3~28	-20~+60

※ At 12VDC/10cm.

# Piezoelectric Buzzer Type | 壓電式蜂鳴器

+Piezoelectric sounder external drive 外激式

## ◎ LF-PE14T40A

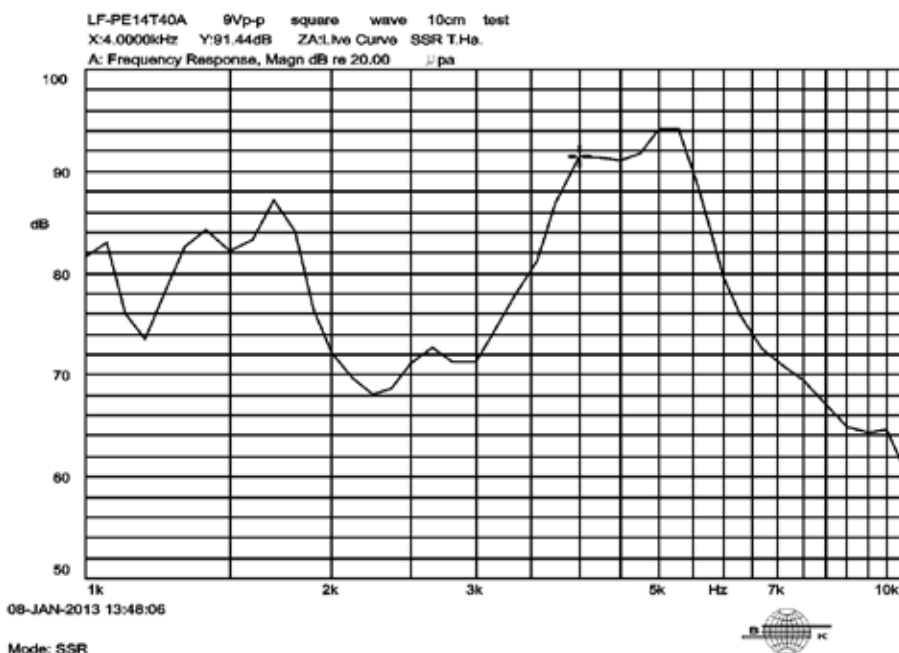
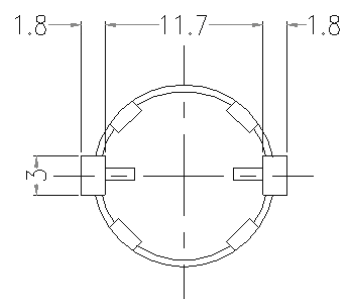
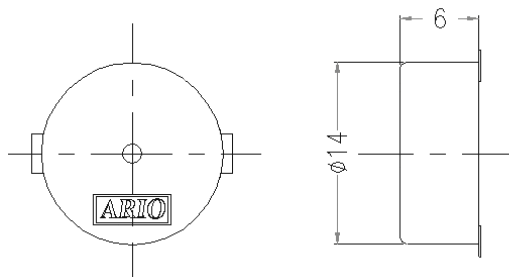

Piezoelectric sounder external drive 外激式

Part No. 型號	Sound Pressure Level (dB min. / 10cm) 輸出音壓	Capacitance (120Hz, 25°C) 靜電容量	Input Voltage (Vp-p) 工作電壓	Operating Temp. (°C) 工作溫度
LF-PE14T40A	85 4000Hz, 9Vp-p square wave	15,000pF±30%	15max.	-20~+85

# Piezoelectric Buzzer Type | 壓電式蜂鳴器

Ariose Electronics Co., Ltd.

+ Piezoelectric sounder external drive 外激式

## ◎ LF-PE13P40H

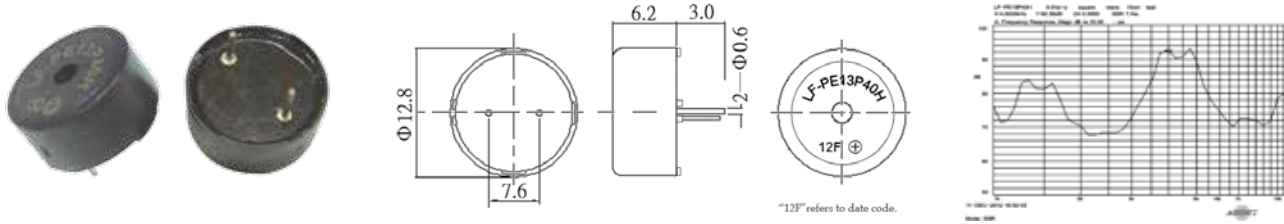

## ◎ LF-PE14P40A-50 / LF-PE14P40A-75 / LF-PE14P40A-100

(Pitch:5.0mm)

(Pitch:7.5mm)

(Pitch:10.0mm)

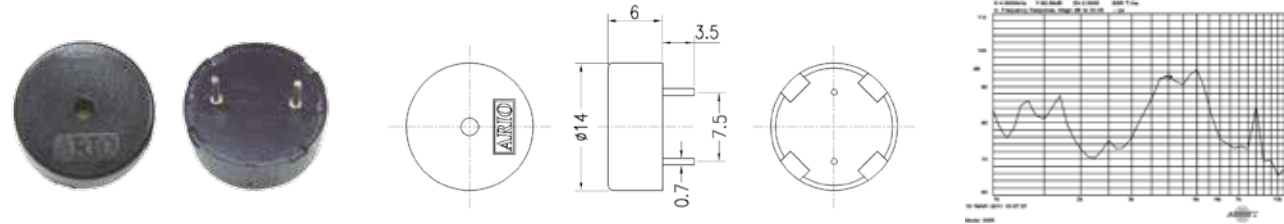

## ◎ LF-PE17P40A-10A / LF-PE17P40A-10B

(Pin-length:6.5mm)

(Pin-length:3.5mm)

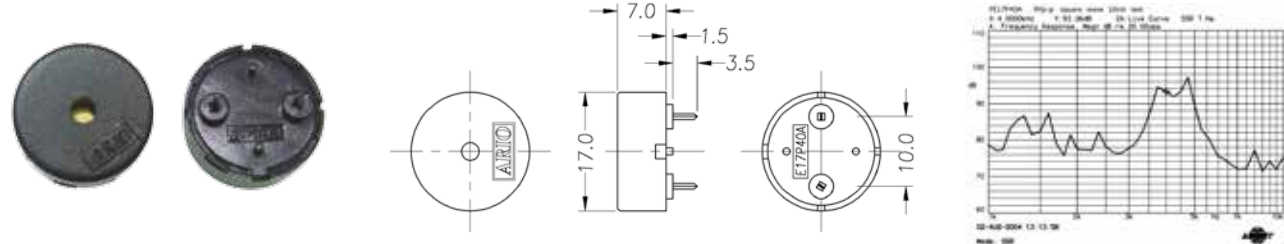

Part No. 型號	Sound Pressure Level (dB min. / 10cm) 輸出音壓	Capacitance (120Hz, 25°C) 靜電容量	Input Voltage (Vp-p) 工作電壓	Operating Temp. (°C) 工作溫度
LF-PE13P40H	89 4000Hz, 9Vp-p square wave	12,000pF±30%	25max.	-20~+70
LF-PE14P40A-50 LF-PE14P40A-75 LF-PE14P40A-100	88 4096Hz, 9Vp-p square wave	18,000pF±30%	20max.	-20~+70
LF-PE17P40A-10A LF-PE17P40A-10B	92 4000Hz, 9Vp-p square wave	14,000pF±30%	20max.	-20~+70

Piezoelectric sounder external drive 外激式

# Piezoelectric Buzzer Type | 壓電式蜂鳴器

## + Piezoelectric sounder external drive 外激式

### ◎ LF-PE22P40A-10A / LF-PE22P40A-10B (Pin-length:6.5mm) (Pin-length:3.5mm)

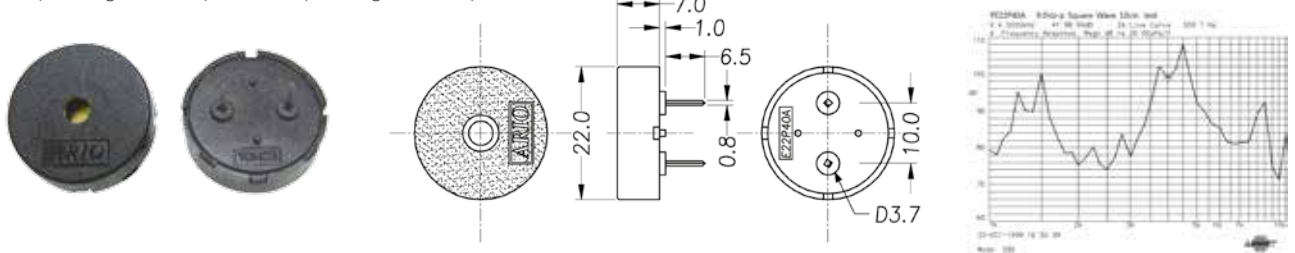

### ◎ LF-PE22P40C-10A / LF-PE22P40C-10B (Pin-length:6.5mm) (Pin-length:3.5mm)

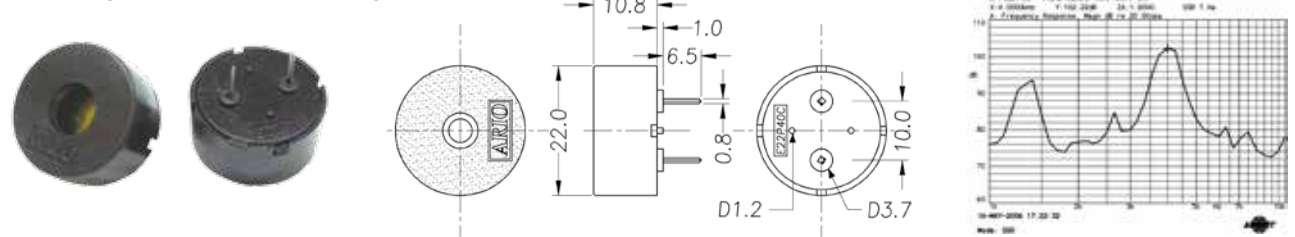

### ◎ LF-PE23P20B

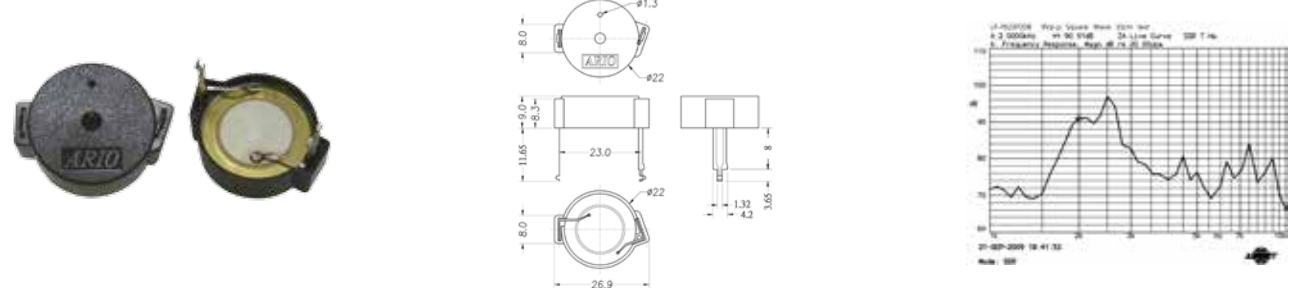

### ◎ LF-PE23S20B

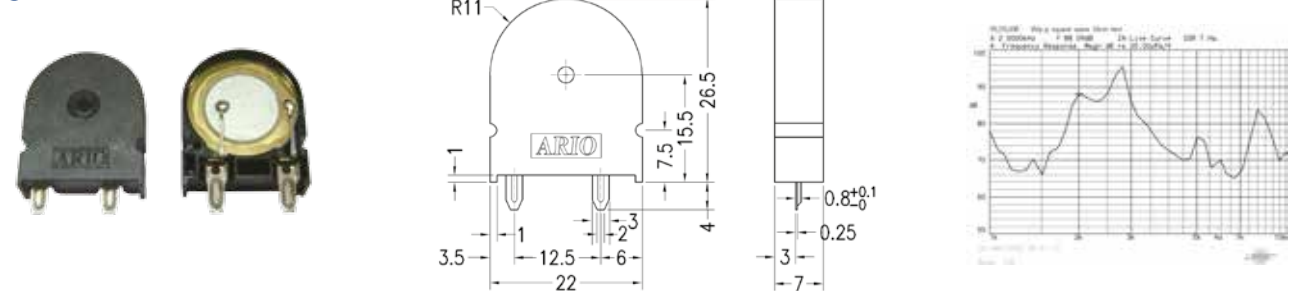

Part No. 型號	Sound Pressure Level (dB min. / 10cm) 輸出音壓	Capacitance (120Hz, 25°C) 靜電容量	Input Voltage (Vp-p) 工作電壓	Operating Temp. (°C) 工作溫度
LF-PE22P40A-10A LF-PE22P40A-10B	90 4000Hz, 9Vp-p square wave	15,000pF±30%	30max.	-20~+70
LF-PE22P40C-10A LF-PE22P40C-10B	102 4000Hz, 9Vp-p square wave	15,000pF±30%	30max.	-20~+70
LF-PE23P20B	88 2000Hz, 9Vp-p square wave	25,000pF±30%	30max.	-20~+70
LF-PE23S20B	88 2000Hz, 9Vp-p square wave	25,000pF±30%	30max.	-20~+70

Piezoelectric sounder external drive 外激式

# Piezoelectric Buzzer Type | 壓電式蜂鳴器

Ariose Electronics Co., Ltd.

+ Piezoelectric sounder external drive 外激式

## ◎ LF-PE24P40A

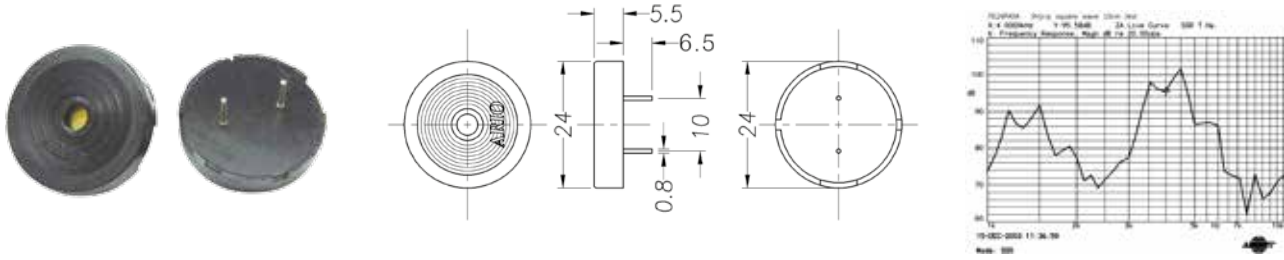

## ◎ LF-PE24P60A

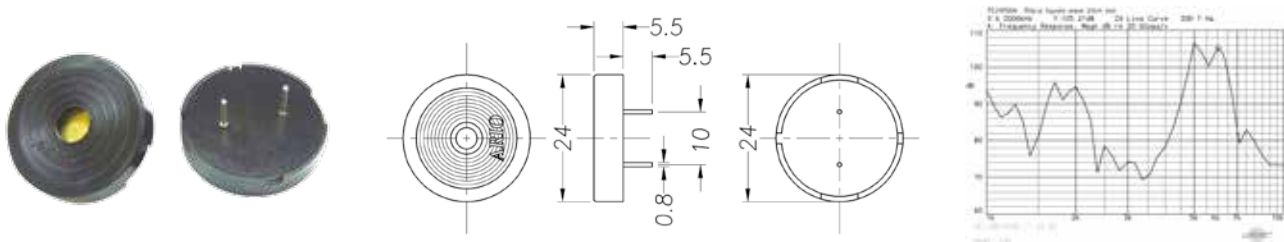

## ◎ LF-PE30P25A-15A / LF-PE30P25A-15B

(Pin-length:6.5mm)

(Pin-length:3.5mm)

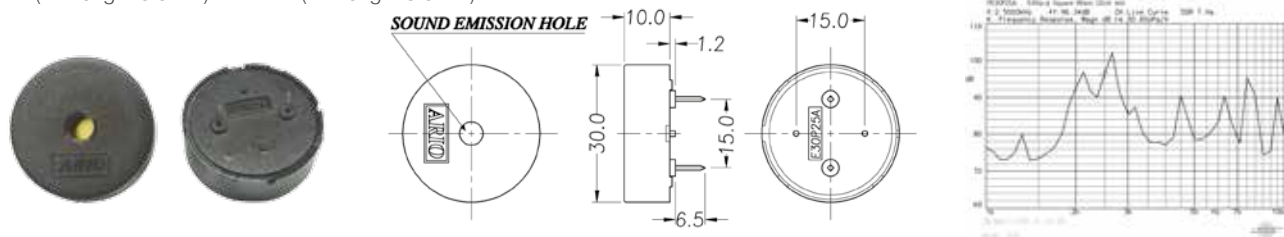

Part No. 型號	Sound Pressure Level (dB min. / 10cm) 輸出音壓	Capacitance (120Hz, 25°C) 靜電容量	Input Voltage (Vp-p) 工作電壓	Operating Temp. (°C) 工作溫度
LF-PE24P40A	94 4000Hz, 9Vp-p square wave	25,000pF±30%	30max.	-20~+70
LF-PE24P60A	90 6000Hz, 9Vp-p square wave	13,000pF±30%	40max.	-20~+70
LF-PE30P25A-15A LF-PE30P25A-15B	92 2500Hz, 9Vp-p square wave	28,000pF±30%	30max..	-20~+85

Piezoelectric sounder external drive 外激式



# Piezoelectric Buzzer Type | 壓電式蜂鳴器

+ Piezoelectric sounder external drive 外激式

Piezoelectric sounder external drive 外激式

## ◎ LF-PE30P38A

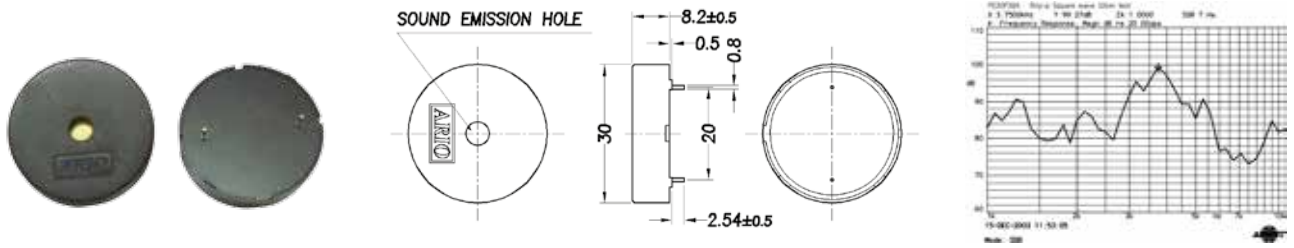

## ◎ LF-PE33P14A

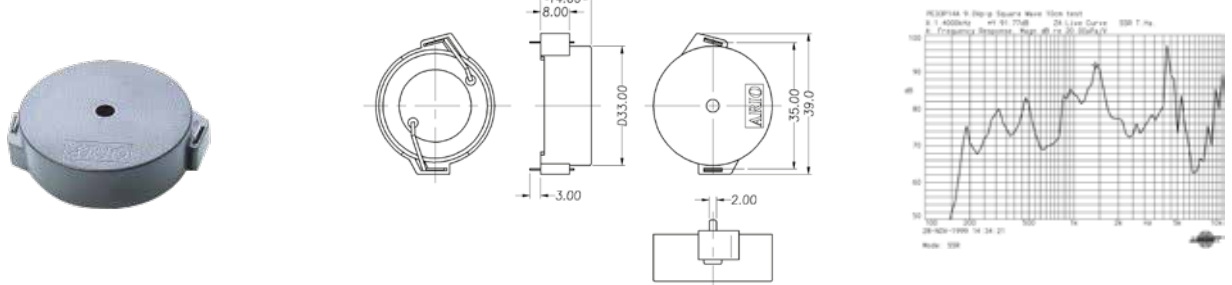

## ◎ LF-PE44P07A

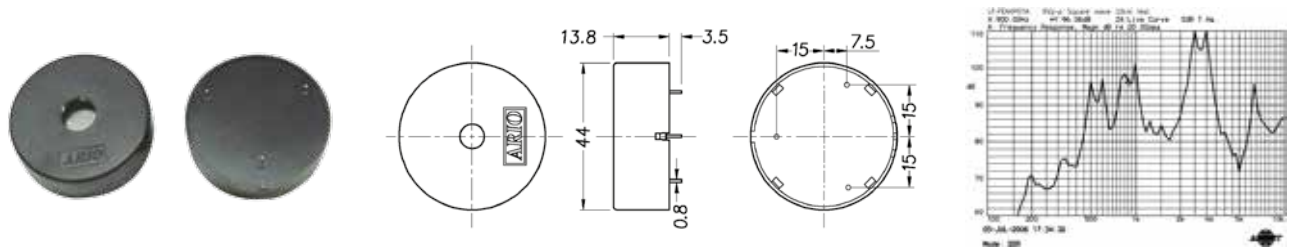

## ◎ LF-PE44P09A

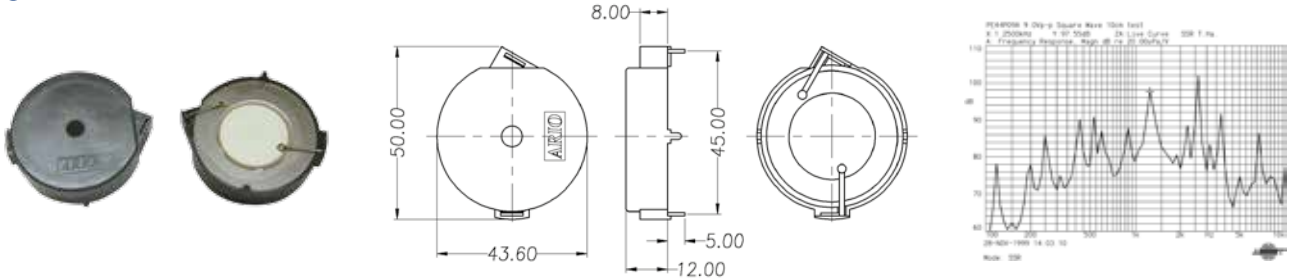

Part No. 型號	Sound Pressure Level (dB min. / 10cm) 輸出音壓	Capacitance (120Hz, 25°C) 靜電容量	Input Voltage (Vp-p) 工作電壓	Operating Temp. (°C) 工作溫度
LF-PE30P38A	92	20,000pF±30%	30max.	-20~+70
	3800Hz, 9Vp-p square wave			
LF-PE33P14A	85	50,000pF±30%	30max.	-20~+70
	1400Hz, 9Vp-p square wave			
LF-PE44P07A	95	90,000pF±30%	40max.	-20~+70
	900Hz, 9Vp-p square wave			
LF-PE44P09A	85	77,000pF±30%	40max.	-20~+70
	1200Hz, 9Vp-p square wave			

# Piezoelectric Buzzer Type | 壓電式蜂鳴器

Ariose Electronics Co., Ltd.

+ Piezoelectric sounder external drive 外激式

## ◎ LF-PE10W32A

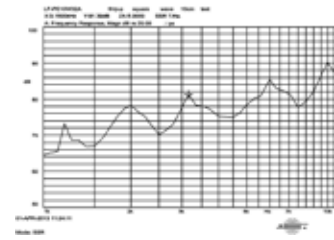
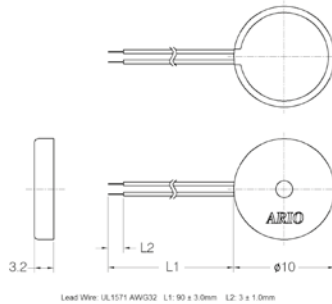

## ◎ LF-PE13W48A

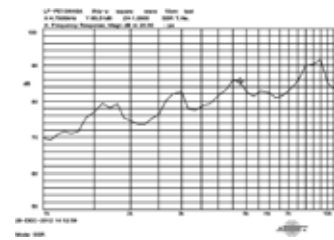
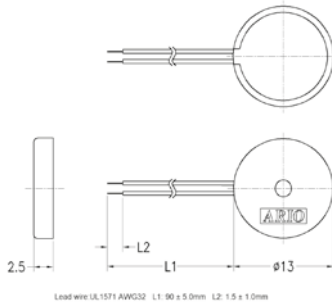

## ◎ LF-PE14W40A

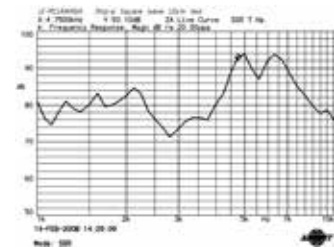
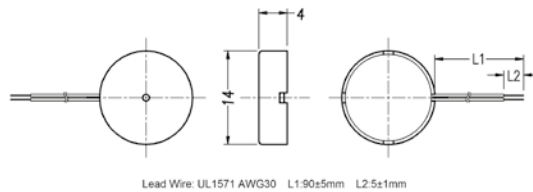

## ◎ LF-PE17W40A-85

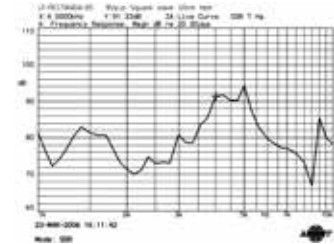
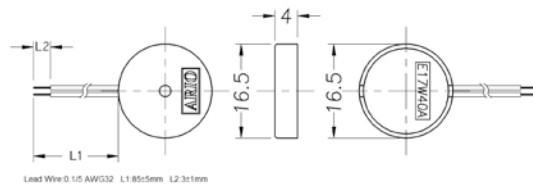

Part No. 型號	Sound Pressure Level (dB min. / 10cm) 輸出音壓	Capacitance (120Hz, 25°C) 靜電容量	Input Voltage (Vp-p) 工作電壓	Operating Temp. (°C) 工作溫度
LF-PE10W32A	75 3200Hz, 9Vp-p square wave	11,000pF ± 30%	30max.	-20~+60
LF-PE13W48A	80 4800Hz, 9Vp-p square wave	15,000pF ± 30%	20max.	-20~+60
LF-PE14W40A	85 4800Hz, 9Vp-p square wave	15,000pF ± 30%	20max.	-20~+70
LF-PE17W40A-85	88 4000Hz, 9Vp-p square wave	14,000pF ± 30%	20max.	-20~+70

Piezoelectric sounder external drive 外激式

# Piezoelectric Buzzer Type | 壓電式蜂鳴器

+ Piezoelectric sounder external drive 外激式

Piezoelectric sounder external drive 外激式

## LF-PE24W40A

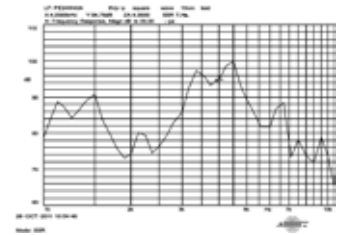
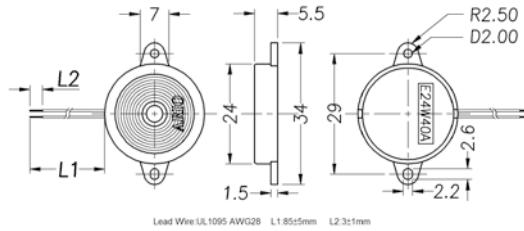

## LF-PE24W60A

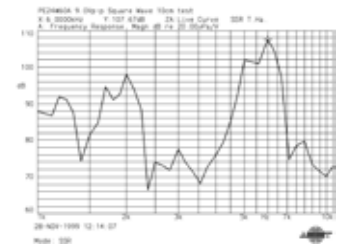
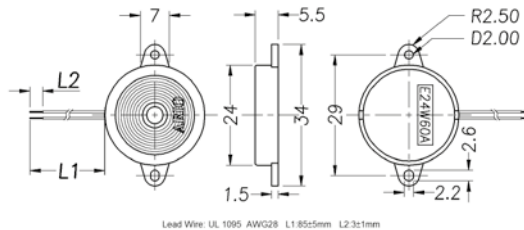

## LF-PE30W25A

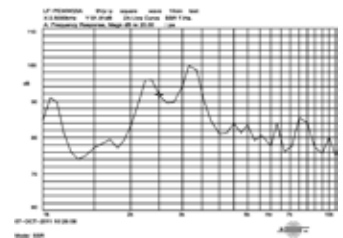
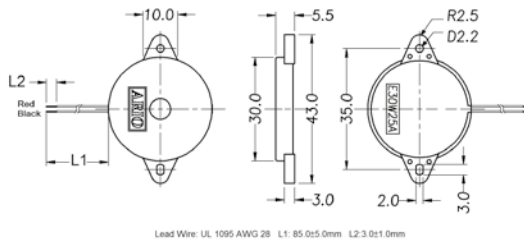
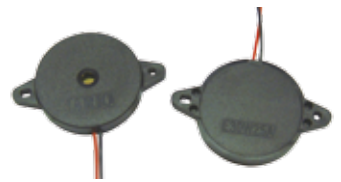

## LF-PE30W40A

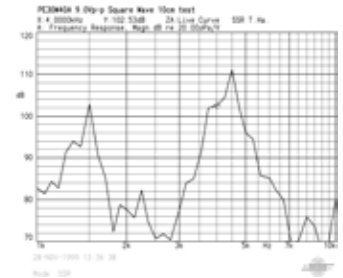
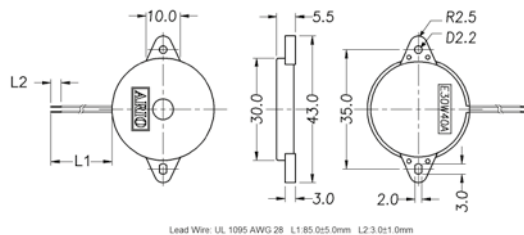

Part No. 型號	Sound Pressure Level (dB min. / 10cm) 輸出音壓	Capacitance (120Hz, 25°C) 靜電容量	Input Voltage (Vp-p) 工作電壓	Operating Temp. (°C) 工作溫度
LF-PE24W40A	90	25,000pF±30%	30max.	-20~+70
	4000Hz, 9Vp-p square wave			
LF-PE24W60A	94	13,000pF±30%	40max.	-20~+70
	6000Hz, 9Vp-p square wave			
LF-PE30W25A	85	47,000pF±30%	20max.	-20~+70
	2500Hz, 9Vp-p square wave			
LF-PE30W40A	96	28,000pF±30%	30max.	-20~+70
	4000Hz, 9Vp-p square wave			

# Piezoelectric Buzzer Type | 壓電式蜂鳴器

Ariose Electronics Co., Ltd.

+ Piezoelectric sounder external drive 外激式

## ◎ LF-PE35W11A-B

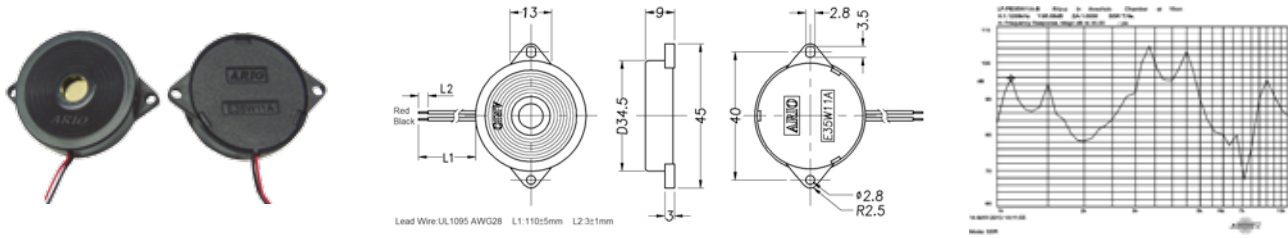

## ◎ LF-PE44W10B-B

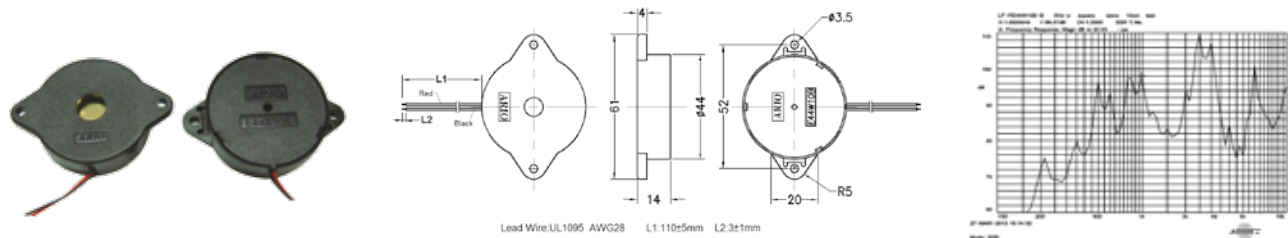

## ◎ LF-PE50W10A-B

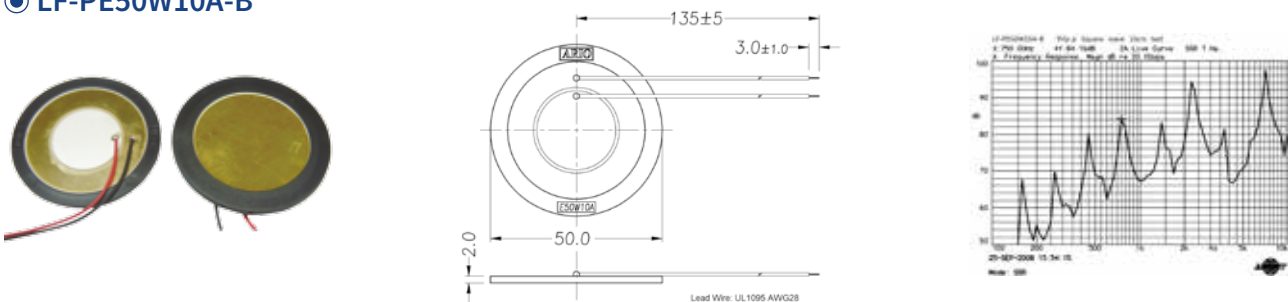

Part No. 型號	Sound Pressure Level (dB min. / 10cm) 輸出音壓	Capacitance (120Hz, 25°C) 靜電容量	Input Voltage (Vp-p) 工作電壓	Operating Temp. (°C) 工作溫度
LF-PE35W11A-B	85 1100Hz, 9Vp-p square wave	50,000pF±30%	40max.	-20~+70
LF-PE44W10B-B	92 1000Hz, 9Vp-p square wave	90,000pF±30%	40max.	-20~+70
LF-PE50W10A-B	78 750Hz, 9Vp-p square wave	90,000pF±30%	40max.	-20~+70

Piezoelectric sounder external drive 外激式

# Piezoelectric Buzzer Type | 壓電式蜂鳴器

+ Piezoelectric sounder self-drive 自激式

## ◎ LF-PS14T40A-A

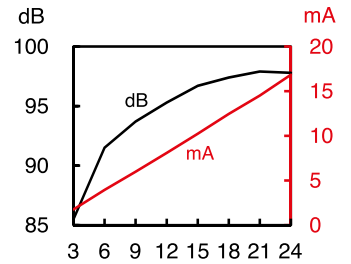
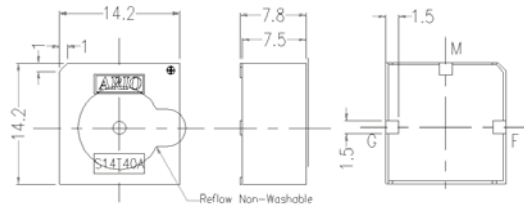

## ◎ LF-PS14P40B

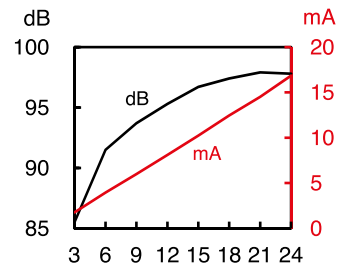
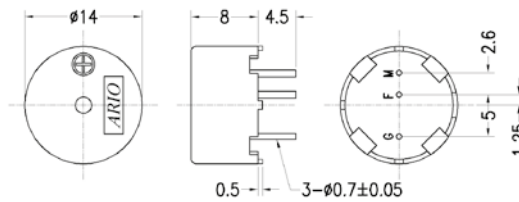
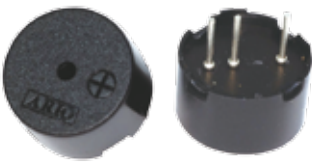

## ◎ LF-PS24P34C-A

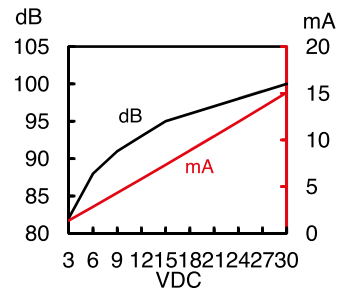
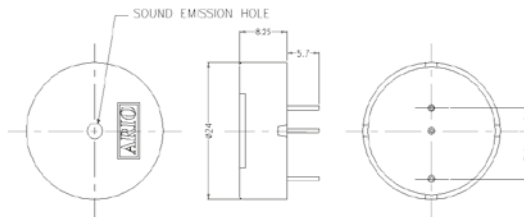

## ◎ LF-PS25P32A

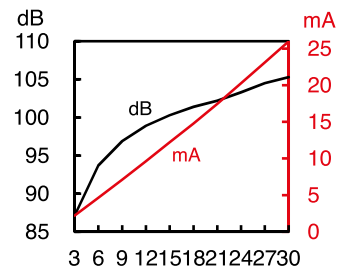
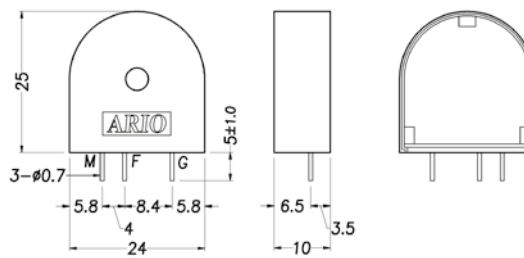

Part No. 型號	※SPL. (dB min.) 輸出音壓	※Current Consumption(mA) 消耗電流	Oscillating Frequency (±0.5KHz) 振盪頻率	Operating Voltage (VDC) 工作電壓	Operating T emp. (°C) 工作溫度
LF-PS14T40A-A	88	8.0 max.	4.5 Continuous tone	3~24	-20~+85
LF-PS14P40B	88	8.0 max.	4.3 Continuous tone	3~24	-20~+85
LF-PS24P34C-A	85	8.0 max.	3.4	3~30	-20~+85
LF-PS25P32A	92	7.0 max.	3.2	3~30	-20~+85

※ 9VDC/10cm by recommended circuit



# Piezoelectric Buzzer Type | 壓電式蜂鳴器

Ariose Electronics Co., Ltd.

+ Piezoelectric sounder self-drive 自激式

## ◎ LF-PS24P34A / LF-PS24P34B / LF-PS24P34A-A / LF-PS24P34A-B

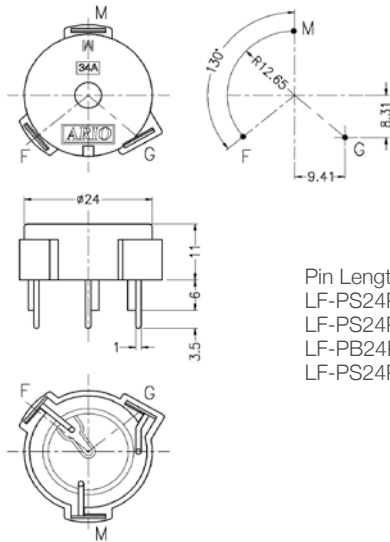

Pin Length:  
 LF-PS24P34A:6.0mm  
 LF-PS24P34B:12.0mm  
 LF-PB24P34A-A:3.0mm  
 LF-PS24P34A-B:4.5mm

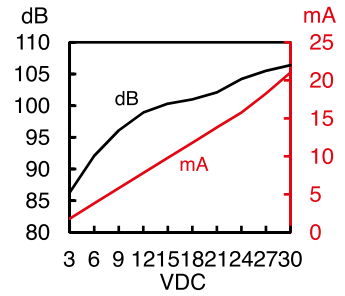

## ◎ LF-PS24P40A / LF-PS24P40B / LF-PS24P40A-A / LF-PS24P40A-B

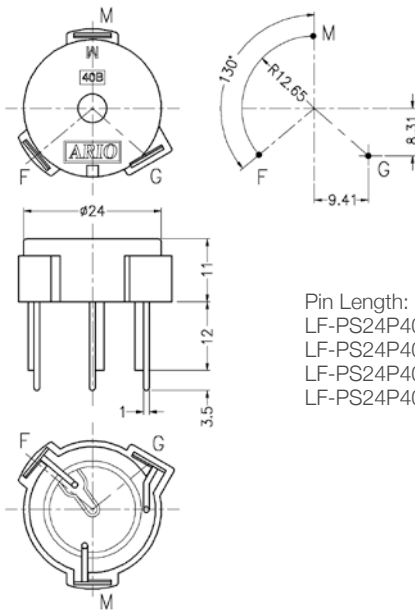

Pin Length:  
 LF-PS24P40A:6.0mm  
 LF-PS24P40B:12.0mm  
 LF-PS24P40A-A:3.0mm  
 LF-PS24P40A-B:4.5mm

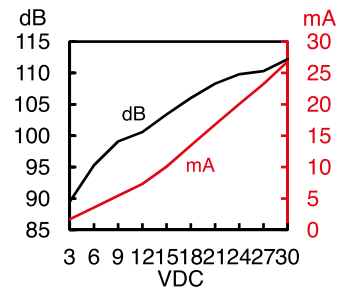

Part No. 型號	※SPL. (dB min.) 輸出音壓	※Current Consumption(mA) 消耗電流	Oscillating Frequency (±0.5KHz) 振盪頻率	Operating Voltage (VDC) 工作電壓	Operating Temp. (°C) 工作溫度
LF-PS24P34A LF-PS24P34B LF-PS24P34A-A LF-PS24P34A-B	95	8.0 max.	3.4	3~30	-20~+70
LF-PS24P40A LF-PS24P40B LF-PS24P40A-A LF-PS24P40A-B	95	8.0 max.	4.0	3~30	-20~+70

※ 9VDC/10cm by recommended circuit

Piezoelectric sounder self drive 自激式



# Piezoelectric Buzzer Type | 壓電式蜂鳴器

+ Piezoelectric sounder self-drive 自激式

## ◎ LF-PS30P26A

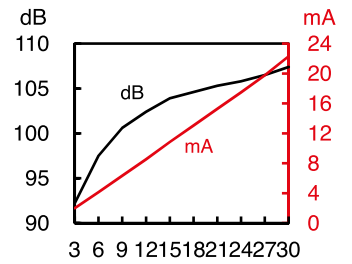
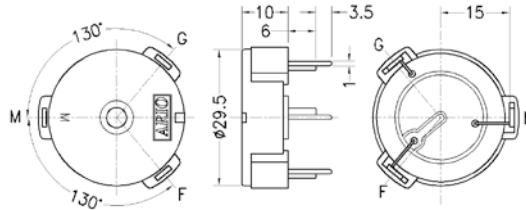

## ◎ LF-PS30P37A

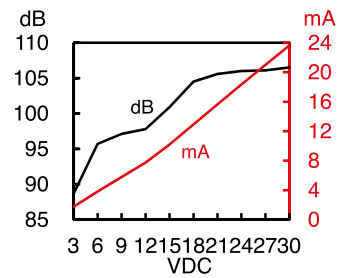
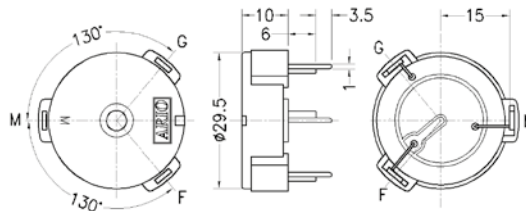

## ◎ LF-PS39P34A

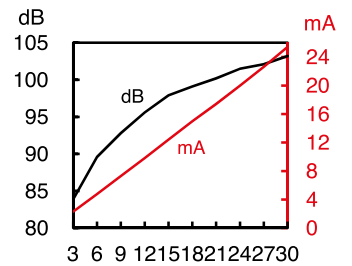
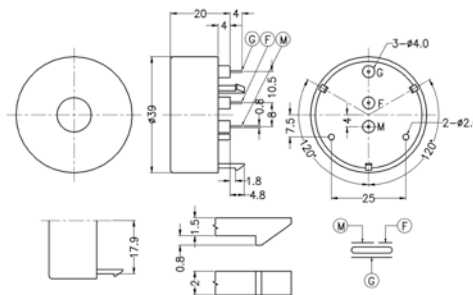

Piezoelectric sounder self drive 自激式

Part No. 型號	※SPL. (dB min.) 輸出音壓	※Current Consumption(mA) 消耗電流	Oscillating Frequency (±0.5KHz) 振盪頻率	Operating Voltage (VDC) 工作電壓	Operating Temp. (°C) 工作溫度
LF-PS30P26A	94	8.0 max.	2.6	3~30	-20~+70
LF-PS30P37A	96	8.0 max.	3.7	3~30	-20~+70
LF-PS39P34A	100	8.0 max.	3.4	3~30	-20~+70

※ 9VDC/10cm by recommended circuit

# Piezoelectric Buzzer Type | 壓電式蜂鳴器

Ariose Electronics Co., Ltd.

+ Piezoelectric sounder self-drive 自激式

## ◎ LF-PS24W34A

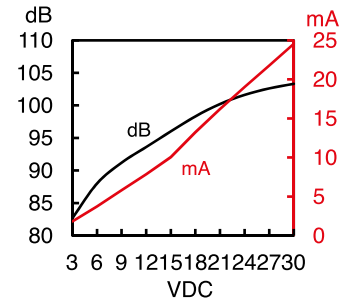
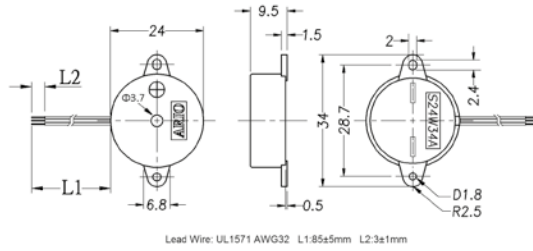

## ◎ LF-PS24W65A

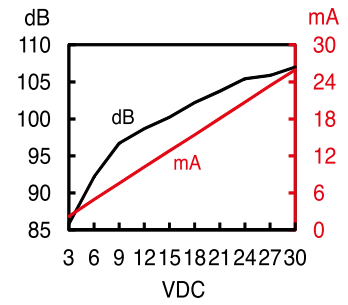
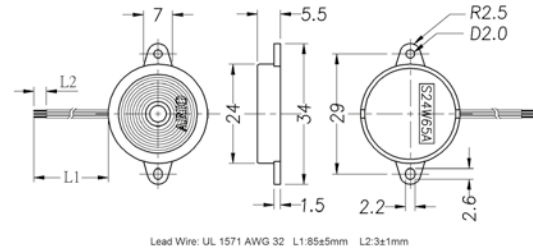

Piezoelectric sounder self drive 自激式

Part No. 型號	※SPL. (dB min.) 輸出音壓	※Current Consumption(mA) 消耗電流	Oscillating Frequency (±0.5KHz) 振盪頻率	Operating Voltage (VDC) 工作電壓	Operating Temp. (°C) 工作溫度
LF-PS24W34A	90	8.0 max.	3.4	3~30	-20~+70
LF-PS24W65A	90	10.0 max.	6.0	3~30	-20~+70

※ 9VDC/10cm by recommended circuit

# Piezoelectric Buzzer Type | 壓電式蜂鳴器

+ Piezoelectric speaker 壓電喇叭

## ◎ LF-PK35W01A

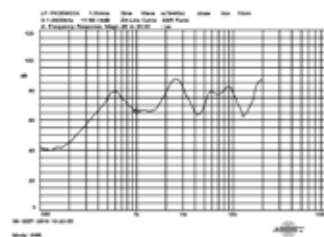
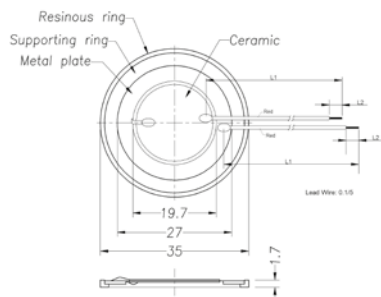
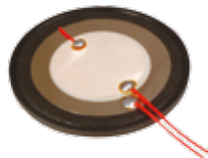

## ◎ LF-PK35W02A

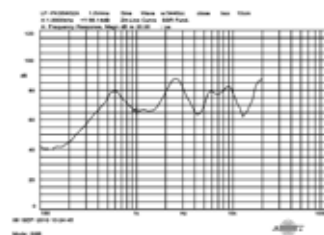
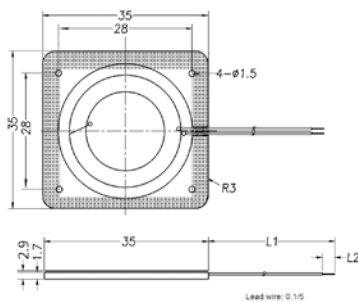

Piezoelectric speaker

壓電喇叭

Part No. 型號	※SPL. (dB min.) 輸出音壓	Freq. Range(Hz.) 頻率範圍	Capacitance (at 120Hz) 靜電容量	Max. Input Voltage (Vp-p) 最大輸入電壓	Operating T emp. (°C) 工作溫度
LF-PK35W01A	77dB min. (500~4KHz ave.)	500~10KHz	180nF±30%	7 Vrms (sine wave)	-20°C ~+80°C
LF-PK35W02A	77dB min. (500~4KHz ave.)	500~10KHz	180nF±30%	7 Vrms (sine wave)	-20°C ~+80°C

※ Input 1.0Vrms sine wave ,10cm by close box 3440cc

+ Piezoelectric speaker 壓電喇叭

## ◎ LF-PK32W20A / LF-PK32W28A(For Alarm Device)

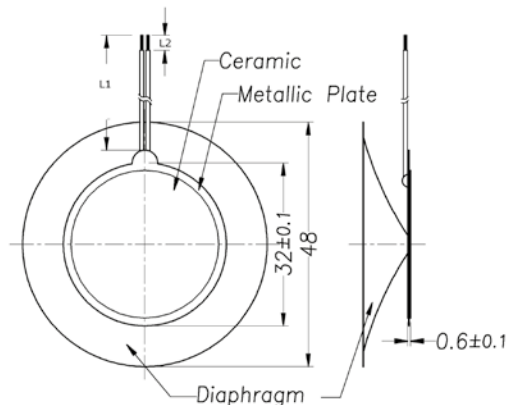

Lead Wire: UL1095 AWG28

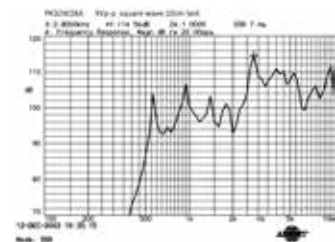
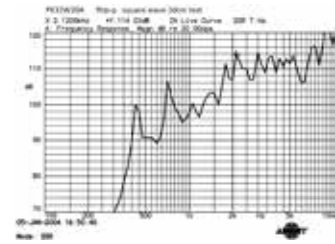

## ◎ LF-PK50W01A / LF-PK50W02A(For Alarm Device)

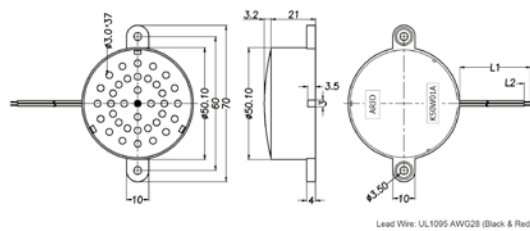

Lead Wire: UL1095 AWG28 (Black & Red)

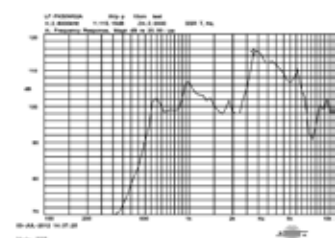
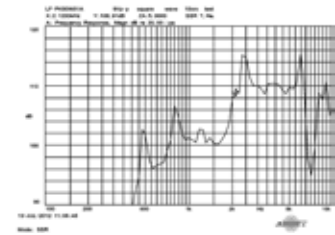

Piezoelectric speaker 壓電喇叭

Part No. 型號	※SPL. (dB min.) 輸出音壓	Freq. Range(Hz.) 頻率範圍	Capacitance (at 120Hz) 靜電容量	Max. Input Voltage (Vp-p) 最大輸入電壓	Operating Temp. (°C) 工作溫度
LF-PK32W20A	105dB min. (2120Hz)	500~10KHz	230nF±30%	60Vp-p (square wave)	-20°C ~+70°C
LF-PK32W28A	105dB min. (2800Hz)	500~10KHz	130nF±30%	60Vp-p (square wave)	-20°C ~+70°C
LF-PK50W01A	98dB min. (2120Hz)	500~10KHz	230nF±30%	60Vp-p (square wave)	-20°C ~+70°C
LF-PK50W02A	105dB min. (2800Hz)	500~10KHz	130nF±30%	60Vp-p (square wave)	-20°C ~+70°C

※ At 9Vp-p square wave, 10cm

## Piezoelectric Type

Description of Part No. of Piezoelectric type series

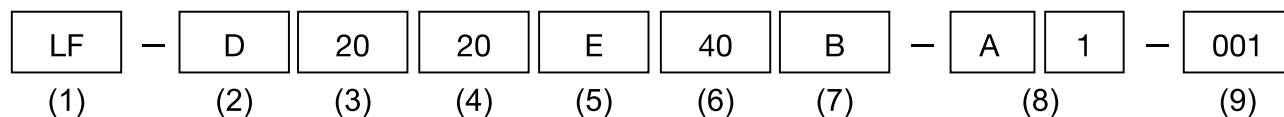

(1) LF : Compliant with RoHS requirement.

  : Not compliant with RoHS requirement.

(2) D : Piezo disc.

W : Piezo disc with lead wire.

(3) Diameter of metal plate (mm) : for round type ; the length of square type, rectangular type , and oval type

(4) Diameter of metal plate (mm) : the width are only for square type, rectangular type and oval type

(5) E: External drive type

S: Self drive type

K: For Piezo speaker

(6) Resonant Frequency (KHz)

i.e.: 2.5KHz will be indicated as 25 ; 700Hz will be 07 ; 11.5KHz will be 115.

(7) Material of metal plate

◆ A : Alloy

◆ B : Brass

◆ S : Stainless steel

(8) Serial number of Piezo disc.

(9) Serial number of Piezo disc with lead wire.

Remark: Piezoelectric ceramic is not in the list of restricted Part No. of RoHS.

## Piezoelectric Ceramic Element

Part No.	Resonant Frequency (KHz)	Resonant Impedance ( $\Omega$ ) (Max.)	Capacitance ( $\mu$ F) $\pm$ 30%	Type	Dimension (mm)				Material of metal plate
					D	d	T	t	
D11E58A-C	5.8 $\pm$ 0.5	400	28,000	A	11.0	9.0	0.09	0.05 $\pm$ 0.01	Iron Nickel Alloy
D12E56B-C	5.6 $\pm$ 0.5	600	15,000	A	12.0	9.0	0.12	0.06 $\pm$ 0.01	Brass
D12S52A-C	5.2 $\pm$ 0.3	600	12,000	B	12.0	9.0	0.10	0.05 $\pm$ 0.01	Iron Nickel Alloy
D14E60B-C	6.0 $\pm$ 0.5	1,000	11,000	A	13.5	10.0	0.14	0.05 $\pm$ 0.02	Brass
D15E40B-C	4.0 $\pm$ 0.5	500	34,000	A	15.0	12.0	0.14	0.08 $\pm$ 0.02	Brass
D15E60B	6.0 $\pm$ 1.0	1,000	15,000	A	15.0	11.3	0.23	0.10 $\pm$ 0.03	Brass
D20E40B	4.0 $\pm$ 0.5	600	28,000	A	20.0	15.0	0.20	0.10 $\pm$ 0.03	Brass
D20E65B	6.5 $\pm$ 0.5	300	15,000	A	20.0	15.0	0.42	0.21 $\pm$ 0.03	Brass
D20S65B-3	6.5 $\pm$ 0.5	500	14,000	B	20.0	15.0	0.42	0.20 $\pm$ 0.03	Brass
D21E34B	3.4 $\pm$ 0.5	600	35,000	A	21.0	15.0	0.18	0.10 $\pm$ 0.03	Brass
D21S36B-C	3.6 $\pm$ 0.3	800	18,000	B	21.0	15.0	0.26	0.15 $\pm$ 0.03	Brass
D23E42B-C	4.2 $\pm$ 0.5	600	15,000	A	22.8	15.0	0.40	0.20 $\pm$ 0.03	Brass
D27S27B-A	2.7 $\pm$ 0.5	300	45,000	B	27.0	20.0	0.30	0.20 $\pm$ 0.05	Brass
D27E40B-3	4.0 $\pm$ 0.5	500	28,000	A	27.0	19.8	0.42	0.20 $\pm$ 0.03	Brass
D31E15A-C	1.5 $\pm$ 0.5	500	70,000	A	31.0	25.0	0.21	0.10 $\pm$ 0.01	Iron Nickel Alloy
D35S27B-A	2.7 $\pm$ 0.3	300	26,000	B	35.0	25.0	0.51	0.30 $\pm$ 0.05	Brass
D35E30B-A	3.0 $\pm$ 0.3	300	40,000	A	35.0	25.0	0.56	0.30 $\pm$ 0.05	Brass
D50E10B	1.0 $\pm$ 0.3	600	65,000	A	50.0	30.0	0.40	0.20 $\pm$ 0.03	Brass

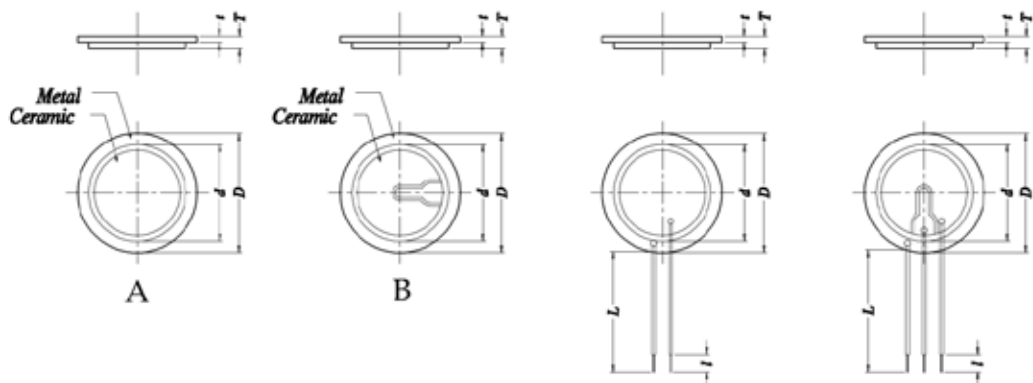

Piezoelectric ceramic element 壓電陶瓷蜂鳴器





**Ariose Electronics Co., Ltd.**

2F-6, No. 40-2, Sec. 1, Minsheng N.Rd., Gueishan, Taoyuan 33391, Taiwan  
33391桃園市龜山區民生北路一段40-2號2樓之6

Tel : 886-3-355-0536 Fax : 886-3-355-4855

E-Mail : [ario@ms10.hinet.net](mailto:ario@ms10.hinet.net) Website : [www.ario.com.tw](http://www.ario.com.tw)